

AirDisk SATAIII M.2 2280 SSD S58C Datasheet

**Version: A0
2021.04**

Revision History

<i>Revision Number</i>	<i>Description</i>	<i>Revision Date</i>
A0	Initial release.	2021.04

Table of content

- 1. General Description 3
- 2. Mechanical Specification 4
 - 2.1 M.2 2280 SSD physical dimensions and Weight 4
- 3. Product Specifications 5
 - 3.1 System Interface and Configuration 5
 - 3.2 System Performance 5
 - 3.3 Drive Capacity 5
 - 3.4 Supply Voltage 5
 - 3.5 System Power Consumption 6
 - 3.6 System Reliability 6
 - 3.7 Endurance 6
 - 3.8 Environmental Specifications 7
- 4. Electrical Interface Specification 7
 - 4.1 M.2 2280 Pin Assignments 7
- 5. Command Descriptions 9
 - 5.1 Supported ATA Commands 9
 - 5.2 SMART Attributes 10
- 6. Identify Device Data 11
 - 6.1 ATA Command Description: IDENTIFY DEVICE(ECh) 11
 - 6.2 ATA Command Description: SET FEATURES(EFh) 17
- 7. Product Line up 18
 - 7.1 SATA3 M.2 2280 18
- 8 Contact information 18

1. General Description

The AirDisk SSD (Solid State Drive) fully consists of semiconductor devices using NAND Flash Memory which provide high reliability and high performance for a storage media. The SSD doesn't have any moving parts such as platter (disk) and head media, which provides a better solution in a notebook PC, Tablet PC and industrial PC for a storage device providing higher performance, reduced latencies, and a low power consumption in a small form factor. SSD has the same host interface with Hard Disk Drives and has a same physical dimension.

•Capacity

–128/256/512GB is available

•Form Factor

– M.2 2280

•Host interface

- Serial ATA interface of 6.0Gbps
- Complies with ATA/ATAPI-8
- Supports NCQ
- Supports TRIM

•Performance

- 128GB
 - Read: Up to 550MB/s
 - Write: Up to 400MB/s
- 256GB
 - Read: Up to 550MB/s
 - Write: Up to 490MB/s
- 512GB
 - Read: Up to 550MB/s
 - Write: Up to 510MB/s

•Power Consumption

- Active write: 1400mW (512GB)
- Active read: 1400mW (512GB)

•Temperature

- Operating : 0°C to 70°C
- Non-Operating: -40°C to 85°C

•Shock

- Shock : 1500G, duration 0.5ms, Half Sine Wave
- Vibration : 7~800Hz, 3.08Grms, 30min/axis(X,Y,Z)
- * Applicable only for cased product

•MTBF

- 1,500,000 Hours

•Weight

- 128/256/512GB
- Max 8g

•TBW

- 128GB: 64TB
- 256GB: 128TB
- 512GB: 256TB

•SSD Functional Block Diagram

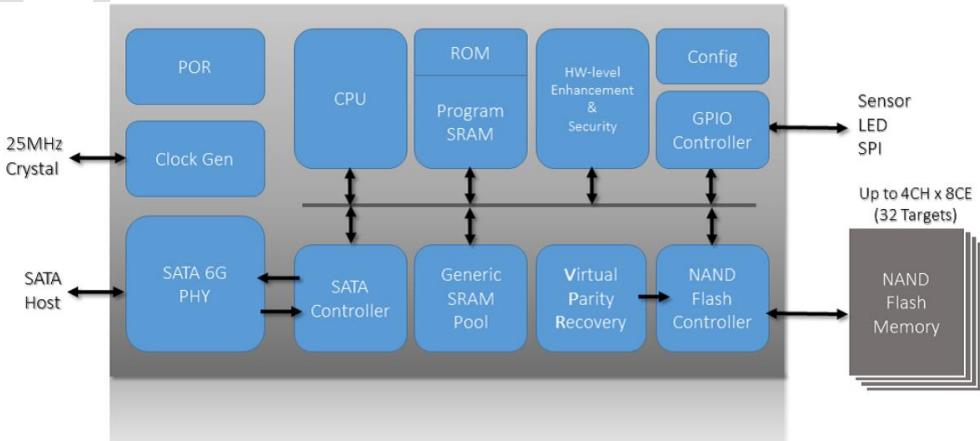

[Figure 1-1] SSD Functional Block Diagram

2. Mechanical Specification

2.1 M.2 2280 SSD physical dimensions and Weight

Capacity	Height (mm)	Width (mm)	Length (mm)	Weight (gram)
128/256/512GB	MAX 2.25	22.00±0.15	80.00±0.15	MAX 8g

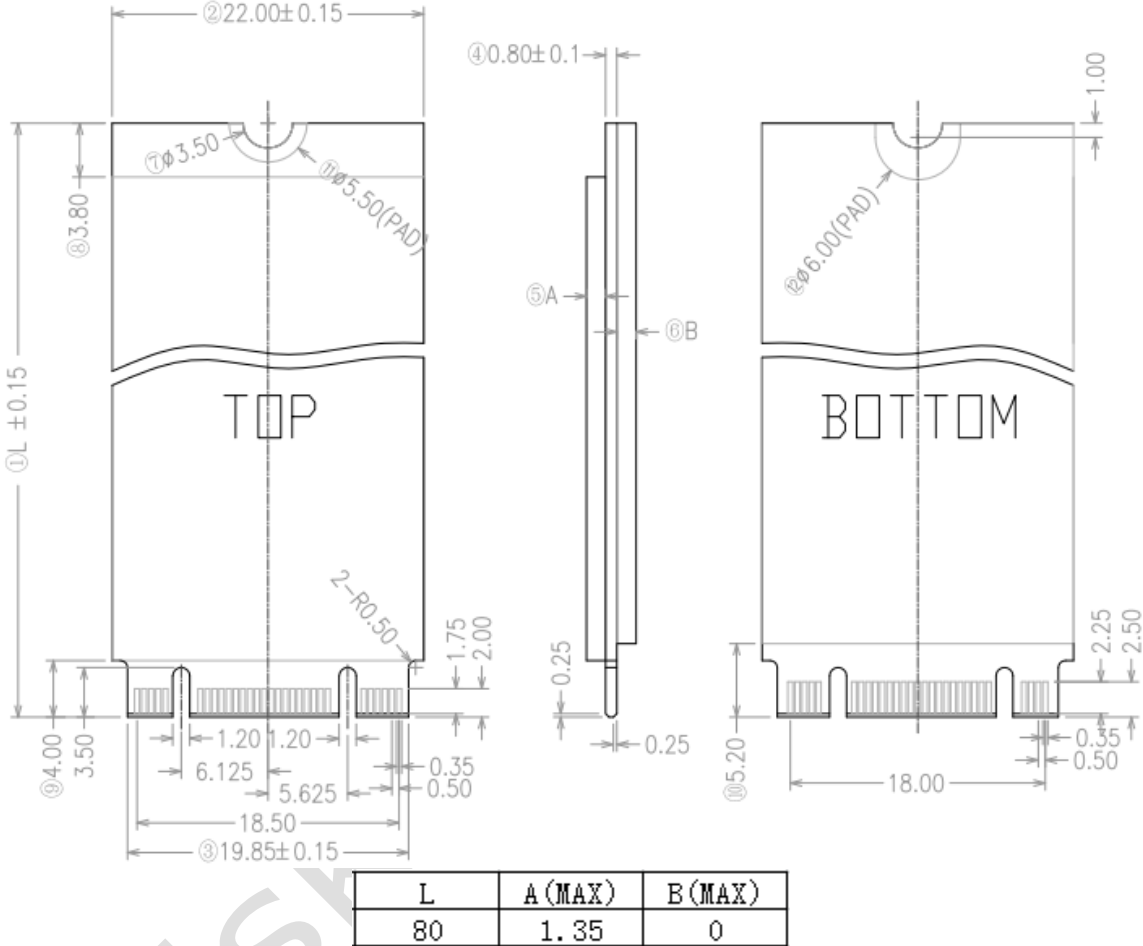

[Figure 2-1] M.2 2280 Physical dimension

3. Product Specifications

3.1 System Interface and Configuration

Burst read/write rate is 600 MB/sec (6.0 Gb/sec).

3.2 System Performance

SATA 6Gb/s host interface				
Parameter	Unit	128GB	256GB	512GB
Sequential Read (Max)	MB/S	550	550	550
Sequential Write (Max)	MB/S	400	490	510
Random Read 4K (Max)	IOPS	60K	84K	85K
Random Write 4K (Max)	IOPS	72K	74K	74K

* Actual performance may vary depending on use conditions and environment

* Note

1. Performance measured using CrystalDiskMark 6.0.2
2. Write cache enabled
3. 1MB/sec = 1,048,576 bytes/sec was used in sequential performance
 - System: Intel Z170 Chipset, Intel Core i5-6600K@3.5GHz, 4GB DDR4
 - OS: Windows 10 x64

3.3 Drive Capacity

Nominal Capacity	128GB	256GB	512GB
Unformatted Capacity	119.24GB	238.47GB	476.94
User-Addressable Sectors	250069680	500118192	1000215216
Bytes per Sector	512 Bytes		

NOTE:

1 Megabyte (MB) = 1 Million bytes; 1 Gigabyte (GB) = 1 Billion bytes

*Actual usable capacity may be less (due to formatting, partitioning, operating system, applications or otherwise)

3.4 Supply Voltage

Item	Requirements
Allowable voltage	3.3V ± 5%
Allowable noise/ripple	100mV p-p or less

3.5 System Power Consumption

Input Voltage 3.3±5% (V)			
Parameter	128GB	256GB	512GB
Sequential Read	1300 mW	1350 mW	1400 mW
Sequential Write	1340 mW	1390 mW	1400 mW
Idle	600 mW	600 mW	600 mW

CPU : Intel Core i5-6600K
 DRAM : 4GB DDR4
 Chipset : Intel Z170
 OS : Windows 10 x64
 Test Tool : CrystalDiskMark 6.0.2

3.6 System Reliability

Capacity	MTBF
128GB	1,500,000 Hours
256GB	
512GB	

MTBF is Mean Time Between Failure. As same word, annual failure ratio is 0.4%.

3.7 Endurance

TBW		
128GB	256GB	512GB
64TB	128TB	256TB

[Table 3-7] Endurance Specifications

Notes:

- 1-TBW (Terabytes Written) is a measurement of SSDs’ expected lifespan, which represents the amount of data written to the device. To calculate the TBW of a SSD, the following equation is applied:

$$TBW = [(NAND\ Endurance) \times (SSD\ Capacity)] / WAF$$

NAND Endurance: NAND endurance refers to the P/E (Program/Erase) cycle of a NAND flash.
SSD Capacity: The SSD capacity is the specific capacity in total of a SSD.
WAF: Write Amplification Factor (WAF) is a numerical value representing the ratio between the amount of data that a SSD controller needs to write and the amount of data that the host’s flash controller writes. A better WAF, which is near 1, guarantees better endurance and lower frequency of data written to flash memory.
- 2-The above TBW values are calculated based on WAF=1.
- 3-TBW may differ according to flash configuration and platform.
- 4-The endurance of SSD could be estimated based on user behavior, NAND endurance cycles, and write amplification factor. It is not guaranteed by flash vendor.

3.8 Environmental Specifications

Features	Operating	Non-Operating
Temperature	0°C to 70°C	-40°C to 85°C
Humidity	5% to 95%, non-condensing	
Vibration	7~800Hz, 3.08Grms, 30min/axis(X,Y,Z)	
Shock	1500G, duration 0.5ms, Half Sine Wave	

Notes:

1-Temperature is measured by SMART Temperature .Proper airflow recommended.

2-Humidity is measured in non-condensing

3-Test condition for shock: 0.5ms duration with half sine wave

4-Test condition for vibration: 10Hz to 2,000Hz, 15mins/axis on 3axis

4. Electrical Interface Specification

4.1 M.2 2280 Pin Assignments

Pin #	Type	Description	Pin #	Type	Description
1	GND	Ground	2	3.3V	Supply pin, 3.3V +/- 5% @ 0.5 Amps
3	GND	Ground	4	3.3V	Supply pin, 3.3V +/- 5% @ 0.5 Amps
5	GND	Ground	6	no connect	
7	no connect		8	no connect	
9	no connect		10	DAS/DSS	Device Activity / Disable Staggered Spin-up
11	no connect		12	no connect	
13	no connect		14	no connect	
15	no connect		16	no connect	
17	no connect		18	no connect	
19	no connect		20	no connect	
21	no connect		22	no connect	
23	no connect		24	no connect	
25	no connect		26	no connect	
27	GND	Ground	28	no connect	
29	no connect		30	no connect	
31	no connect		32	no connect	
33	GND	Ground	34	no connect	
35	no connect		36	no connect	
37	no connect		38	DEVSLP	0 / 1.8V DEVSLP(device sleep mode)enable.

39	GND	Ground	40	no connect	
41	SATA-B+	Host receiver differential signal pair	42	no connect	
43	SATA-B-	Host receiver differential signal pair	44	no connect	
45	GND		46	no connect	
47	SATA-A-	Host transmitter differential signal pair	48	no connect	
49	SATA-A+	Host transmitter differential signal pair	50	no connect	
51	GND	Ground	52	no connect	
53	no connect		54	no connect	
55	no connect		56	no connect	
57	GND	Ground	58	no connect	
59	no connect		60	no connect	
61	no connect		62	no connect	
63	no connect		64	no connect	
65	no connect		66	no connect	
67	no connect		68	no connect	
69	GND	Ground	70	3.3V	Supply pin, 3.3V +/- 5% @ 0.5 Amps
71	GND	Ground	72	3.3V	Supply pin, 3.3V +/- 5% @ 0.5 Amps
73	GND	Ground	74	3.3V	Supply pin, 3.3V +/- 5% @ 0.5 Amps
75	GND	Ground			

Table 4-1: M.2 2280 Connector Pin Assignment

5. Command Descriptions

5.1 Supported ATA Commands

This table with the following paragraphs summarizes the ATA command set.

Table 5 ATA Command List

Command Name	Code	PARAMETERS USED					
		SC	SN	CY	DR	HD	FT
CHECK POWER MODE	E5h	X	X	X	O	X	X
EXECUTE DIAGNOSTICS	90h	X	X	X	O	X	X
FLUSH CACHE	E7h	X	X	X	O	O	X
IDENTIFY DEVICE	ECh	X	X	X	O	X	X
IDLE	E3h	O	X	X	O	X	X
IDLE IMMEDIATE	E1h	X	X	X	O	X	X
INITIALIZE DEVICE PARAMETERS	91h	O	X	X	O	O	X
READ DMA	C8h	O	O	O	O	O	X
READ DMA EXT	25h	O	O	O	O	O	X
READ FPDMA QUEUED	60h	O	O	O	O	O	X
READ LOG DMA EXT	47h	O	O	O	O	O	X
READ LOG EXT	2Fh	O	O	O	O	O	X
READ MULTIPLE	C4h	O	O	O	O	O	X
READ SECTOR(S)	20h or 21h	O	O	O	O	O	X
READ VERIFY SECTOR(S)	40h or 41h	O	O	O	O	O	X
RECALIBRATE	10h	X	X	X	O	X	X
SECURITY DISABLE PASSWORD	F6h	X	X	X	O	X	X
SECURITY ERASE PREPARE	F3h	X	X	X	O	X	X
SECURITY ERASE UNIT	F4h	X	X	X	O	X	X
SECURITY FREEZE LOCK	F5h	X	X	X	O	X	X
SECURITY SET PASSWORD	F1h	X	X	X	O	X	X
SECURITY UNLOCK	F2h	X	X	X	O	X	X
SEEK	7xh	X	X	O	O	O	X
SET FEATURES	EFh	O	X	X	O	X	O
SET MULTIPLE MODE	C6h	O	X	X	O	X	X
SLEEP	E6h	X	X	X	O	X	X
SMART	B0h	X	X	O	O	X	O
STANDBY	E2h	X	X	X	O	X	X
STANDBY IMMEDIATE	E0h	X	X	X	O	X	X
WRITE DMA	CAh	O	O	O	O	O	X
WRITE DMA EXT	35h	O	O	O	O	O	X
WRITE FPDMA QUEUED	61h	O	O	O	O	O	X
WRITE LOG DMA EXT	57h	O	O	O	O	O	X
WRITE LOG EXT	3Fh	O	O	O	O	O	X
WRITE MULTIPLE	C5h	O	O	O	O	O	X
WRITE SECTOR(S)	30h or 31h	O	O	O	O	O	X

Note:

O = Valid, X = Don't care

SC = Sector Count Register

SN = Sector Number Register

CY = Cylinder Low/High Register

DR = DEVICE SELECT Bit (DEVICE/HEAD Register Bit 4)

HD = HEAD SELECT Bit (DEVICE/HEAD Register Bit 3-0)

FT = Features Register

5.2 SMART Attributes

The following table defines the vendor specific data in byte 2 to 361 of the 512-byte SMART data.

SMART Data Vendor-specific Attributes

Attribute ID (hex)	Attribute Name
05	New Bad Block Count
09	Power On Hours
0C	Power Cycle Count
C0	Unexpected Power Loss Count
C2	Temperature
C7	UltraDMA CRC Error Count
CE	Minimum Erase Count
CF	Maximum Erase Count
D0	Average Erase Count
F1	Total LBA written
F2	Total LBA read

6. Identify Device Data

6.1 ATA Command Description: IDENTIFY DEVICE(ECh)

This commands read out 512Bytes of drive parameter information. Parameter Information consists of the arrangement and value as shown in the following table. This command enables the host to receive the Identify Drive Information from the device.

Table 6 IDENTIFY DEVICE (ECh) information default value

Word	Value	F/V	Description
0	0040h	F	15 0 = ATA device
		X	14-8 Retired
		F	7 1 = removable media device
		X	6 Obsolete
		X	5-3 Retired
		F	2 Reserved
		X	1 Retired
		F	0 Reserved
		1	XXXXh
2	C837h	V	Specific configuration
3	00XXh	X	Number of logical heads
4-5	XXXXh	X	Retired
6	XXXXh	X	Number of logical sector per logical track
7-8	XXXXh	V	Reserved for assignment by the CompactFlash_ Association
9	000Eh	X	Retired
10-19	XXXXh	F	Serial number (20 ASCII characters)
20-21	XXXXh	X	Retired
22	003Fh	X	Obsolete



Table 6 IDENTIFY DEVICE (ECh) information default value

Word	Value	F/V	Description
23-26	XXXXh	F	Firmware revision (8 ASCII characters)
27-46	XXXXh	F	Model number (40 ASCII characters)
47	8000h	F	15-8 80h
		F	7-0 00h = Reserved
		F	01h = Maximum number of 1 sectors on READ/WRITE MULTIPLE commands
48	4000h	F	Reserved
49	2F00h	F	Capabilities 15-14 Reserved for the IDENTIFY PACKET DEVICE command.
		F	13 1 = Standby timer values as specified in this standard are supported 0 = Standby timer values shall be managed by the device
		F	12 Reserved for the IDENTIFY PACKET DEVICE command.
		F	11 1 = IORDY supported 0 = IORDY may be supported
		F	10 1 = IORDY may be disabled
		F	9 1 = LBA supported
		F	8 1 = DMA supported.
		X	7-0 Retired
50	4000h	F	Capabilities 15 Shall be cleared to zero.
		F	14 Shall be set to one.
		F	13-2 Reserved.
		X	1 Obsolete
		F	0 Shall be set to one to indicate a device specific Standby timer value minimum.
51-52	0000h	X	Obsolete
53	0007h	F	15-3 Reserved
		F	2 1 = the fields reported in word 88 are valid 0 = the fields reported in word 88 are not valid
		F	1 1 = the fields reported in words 70:64 are valid 0 = the fields reported in words 70:64 are not valid
		X	0 1 = the fields reported in words 58:54 are valid 0 = the fields reported in words 58:54 are not valid
54-58	XXXXh	X	Obsolete
59	0000h	F	15-9 Reserved
		V	8 1 = Multiple sector setting is valid
		V	7-0 xxh = Setting for number of sectors that shall be transferred per interrupt on R/W Multiple command
60-61	XXXXh	F	Total number of user addressable sectors
62	0000h	X	Obsolete
63	0007h	F	15-11 Reserved
		V	10 1 = Multiword DMA mode 2 is selected 0 = Multiword DMA mode 2 is not selected
		V	9 1 = Multiword DMA mode 1 is selected 0 = Multiword DMA mode 1 is not selected

Table 6 IDENTIFY DEVICE (ECh) information default value

Word	Value	F/V	Description
		V	8 1 = Multiword DMA mode 0 is selected 0 = Multiword DMA mode 0 is not selected
		F	7-3 Reserved
		F	2 1 = Multiword DMA mode 2 and below are supported
		F	1 1 = Multiword DMA mode 1 and below are supported
		F	0 1 = Multiword DMA mode 0 is supported
64	0003h	F	15-8 Reserved
		F	7-0 Advanced PIO modes supported
65	0078h	F	Minimum Multiword DMA transfer cycle time per word
66	0078h	F	Manufacturer's recommended Multiword DMA transfer cycle time
67	0078h	F	Minimum PIO transfer cycle time without flow control
68	0078h	F	Minimum PIO transfer cycle time with IORDY flow control
69-74	0000h	F	Reserved (for future command overlap and queuing)
75	0000h	F	Queue depth 15:5 Reserved 4:0 Maximum queue depth - 1
76	xh	F	Serial ATA Capabilities 15:13 Reserved for Serial ATA 12 1 = Supports NCQ priority information 11 1 = Supports Unload while NCQ commands are outstanding 10 1 = Supports the SATA Phy Event Counters log 9 1 = Supports receipt of host initiated power management requests 8 1 = Supports the NCQ feature set 7:4 Reserved for Serial ATA 3 1 = Supports SATA Gen3 Signaling Speed (6.0Gb/s) 2 1 = Supports SATA Gen2 Signaling Speed (3.0Gb/s) 1 1 = Supports SATA Gen1 Signaling Speed (1.5Gb/s) 0 Shall be cleared to zero
77			Reserved
78	xh		Serial ATA features supported 15:7 Reserved for Serial ATA 6 1 = Device supports Software Settings Preservation 5 Reserved for Serial ATA 4 1 = Device supports in-order data delivery

Table 6 IDENTIFY DEVICE (ECh) information default value

Word	Value	F/V	Description
			3 1 = Device supports initiating power management 2 1 = Device supports DMA Setup auto-activation 1 1 = Device supports non-zero buffer offsets 0 Shall be cleared to zero
79	xh		Serial ATA features enabled 15:7 Reserved for Serial ATA 6 1 = Software Settings Preservation enabled 5 Reserved for Serial ATA 4 1 = In-order data delivery enabled 3 1 = Device initiated power management enabled 2 1 = DMA Setup auto-activation enabled 1 1 = Non-zero buffer offsets enabled F 0 Shall be cleared to zero
80	01FEh	F 15 Reserved F 14 Reserved for ATA/ATAPI-14 F 13 Reserved for ATA/ATAPI-13 F 12 Reserved for ATA/ATAPI-12 F 11 Reserved for ATA/ATAPI-11 F 10 Reserved for ATA/ATAPI-10 F 9 Reserved for ATA/ATAPI-9 F 8 Reserved for ATA/ATAPI-8 F 7 1 = supports ATA/ATAPI-7 F 6 1 = supports ATA/ATAPI-6 F 5 1 = supports ATA/ATAPI-5 F 4 1 = supports ATA/ATAPI-4 F 3 Obsolete X 2 Obsolete X 1 Obsolete F 0 Reserved	Major version number 0000h or FFFFh = device does not report version
81	0021h	F	Minor version number
82	0068h	X 15 Obsolete F 14 1 = NOP command supported F 13 1 = READ BUFFER command supported F 12 1 = WRITE BUFFER command supported X 11 Obsolete F 10 1 = Host Protected Area feature set supported F 9 1 = DEVICE RESET command supported F 8 1 = SERVICE interrupt supported	Command set supported.

Table 6 IDENTIFY DEVICE (ECh) information default value

Word	Value	F/V	Description
		F	7 1 = release interrupt supported
		F	6 1 = look-ahead supported
		F	5 1 = write cache supported
		F	4 Shall be cleared to zero to indicate that the PACKET Command feature set is not supported.
		F	3 1 = mandatory Power Management feature set supported
		F	2 1 = Removable Media feature set supported
		F	1 1 = Security Mode feature set supported
		F	0 1 = SMART feature set supported
83	5000h	F	Command sets supported.
		F	15 Shall be cleared to zero
		F	14 Shall be set to one
		F	13-9 Reserved
		F	8 1 = SET MAX security extension supported
		F	7 Reserved
		F	6 1 = SET FEATURES subcommand required to spinup after power-up
		F	5 1 = Power-Up In Standby feature set supported
		F	4 1 = Removable Media Status Notification feature set supported
		F	3 1 = Advanced Power Management feature set supported
		F	2 1 = CFA feature set supported
		F	1 1 = READ/WRITE DMA QUEUED supported
		F	0 1 = DOWNLOAD MICROCODE command supported
84	4000h	F	Command set/feature supported extension.
		F	15 Shall be cleared to zero
		F	14 Shall be set to one
		F	13-2 Reserved
		F	1 1 = SMART self-test supported
		F	0 1 = SMART error logging supported
85	0008h	X	Command set/feature enabled.
		F	15 Obsolete
		F	14 1 = NOP command enabled
		F	13 1 = READ BUFFER command enabled
		F	12 1 = WRITE BUFFER command enabled
		X	11 Obsolete
		V	10 1 = Host Protected Area feature set enabled
		F	9 1 = DEVICE RESET command enabled
		V	8 1 = SERVICE interrupt enabled
		V	7 1 = release interrupt enabled
		V	6 1 = look-ahead enabled
		V	5 1 = write cache enabled
		F	4 Shall be cleared to zero to indicate that the PACKET Command feature set is not supported.
		F	3 1 = Power Management feature set enabled
		F	2 1 = Removable Media feature set enabled
		V	1 1 = Security Mode feature set enabled
		V	0 1 = SMART feature set enabled
86	5000h	F	Command set/feature enabled.
		F	15-9 Reserved
		F	8 1 = SET MAX security extension enabled by SET MAX SET PASSWORD

Table 6 IDENTIFY DEVICE (ECh) information default value

Word	Value	F/V	Description
		F	7 See Address Offset Reserved Area Boot, INCITS TR27:2001
		F	6 1 = SET FEATURES subcommand required to spin-up after power-up
		V	5 1 = Power-Up In Standby feature set enabled
		V	4 1 = Removable Media Status Notification feature set enabled
		V	3-1 1 = Advanced Power Management feature set enabled
		F	0 1 = DOWNLOAD MICROCODE command supported
87	4000h		Command set/feature default.
		F	15 Shall be cleared to zero
		F	14 Shall be set to one
		F	13-2 Reserved
		F	1 1 = SMART self-test supported
		F	0 1 = SMART error logging supported
88	xh		15-14 Reserved
		V	13 1 = Ultra DMA mode 5 is selected 0 = Ultra DMA mode 5 is not selected
		V	12 1 = Ultra DMA mode 4 is selected 0 = Ultra DMA mode 4 is not selected
		V	11 1 = Ultra DMA mode 3 is selected 0 = Ultra DMA mode 3 is not selected
		V	10 1 = Ultra DMA mode 2 is selected 0 = Ultra DMA mode 2 is not selected
		V	9 1 = Ultra DMA mode 1 is selected 0 = Ultra DMA mode 1 is not selected
		F	8 1 = Ultra DMA mode 0 is selected
		F	0 = Ultra DMA mode 0 is not selected
		F	7-6 Reserved
		F	5 1 = Ultra DMA mode 5 and below are supported
		F	4 1 = Ultra DMA mode 4 and below are supported
		F	3 1 = Ultra DMA mode 3 and below are supported
			2 1 = Ultra DMA mode 2 and below are supported
			1 1 = Ultra DMA mode 1 and below are supported
			0 1 = Ultra DMA mode 0 is supported
89	0000h	F	Time required for security erase unit completion
90	0000h	F	Time required for Enhanced security erase completion
91	0000h	V	Current advanced power management value
92	0000h	V	Master Password Revision Code
93	0000h	X	Hardware reset result
94-126	0000h	V	Reserved
127	0000h		Removable Media Status Notification feature set support
		F	15-2 Reserved
		F	1-0 00 = Removable Media Status Notification feature set not supported 01 = Removable Media Status Notification feature supported 10 = Reserved 11 = Reserved

Table 6 IDENTIFY DEVICE (ECh) information default value

128	0001h	F	15-9	Reserved
		V	8	Security level 0 = High, 1 = Maximum
		F	7-6	Reserved
		F	5	1 = Enhanced security erase supported
		V	4	1 = Security count expired
		V	3	1 = Security frozen
		V	2	1 = Security locked
		V	1	1 = Security enabled
		F	0	1 = Security supported
		129-159	0000h	X
160-254	0000h	X	Reserved	
255	0000h	X	Integrity word	
			15-8	Checksum
			7-0	Signature

Note:
 F/V = Fixed/variable content
 F = the content of the word is fixed and does not change. For removable media devices, these values may change when media is removed or changed.
 V = the contents of the word is variable and may change depending on the state of the device or the commands executed by the device.
 X = the content of the word may be fixed or variable.

6.2 ATA Command Description: SET FEATURES(EFh)

This command set parameter to Features register and set drive’s operation. For transfer mode, parameter is set to Sector Count Register. This command is used by the host to establish or select certain features.

Table 7 Features Register value and available operating mode

Value	Function
02h	Enable write cache
03h	Set transfer mode based on value in Sector Count register.
55h	Disable read look-ahead feature
82h	Disable write cache
90h	Disable use of SATA feature
AAh	Enable read look-ahead feature

7. Product Line up

7.1 SATA3 M.2 2280

Type	Capacity	MODEL	Part Number
SATA3 M.2 2280 SSD	128GB	S58CF128G	TBD
SATA3 M.2 2280 SSD	256GB	S58CF256G	TBD
SATA3 M.2 2280 SSD	512GB	S58CF512G	TBD

8 Contact information

Tel: +86-755-8616-8848

Fax: +86-755-8616-9388

Email: sales@longsys.com

Website: www.longsys.com

Add: 8/F, 1 Building, Finance Base, No.8, Kefa Road, High-Tech Park, Shenzhen, China