

FORESEE SATAIII M.2 2280 SSD S41C Datasheet

Version: A5

2020.08

Shenzhen Longsys Electronics Co., Ltd, together with any and all of its affiliates (herein after referred as "Longsys" or "Longsys Electronics") LONGSYS RESERVES THE RIGHT TO CHANGE PRODUCTS, INFORMATION AND SPECIFICATIONS WITHOUT NOTICE.

Products and specifications discussed herein are for reference purposes only. All information discussed herein is provided on an "AS IS" basis, without warranties of any kind.

This document and all information discussed herein remain the sole and exclusive property of Longsys. No license of any patent, copyright, mask work, trademark or any other intellectual property right is granted by one party to the other party under this document, by implication, estoppel or otherwise.

Longsys products are not intended for use in life support, critical care, medical, safety equipment, or similar applications where product failure could result in loss of life or personal or physical harm, or any military or defense application, or any governmental procurement to which special terms or provisions may apply.

For updates or additional information about Longsys products, contact your nearest Longsys office.

All brand names, trademarks and registered trademarks belong to their respective owners.

© 2020 Shenzhen Longsys Electronics Co., Ltd. All rights reserved.

Revision History

<i>Revision Number</i>	<i>Description</i>	<i>Revision Date</i>
A5	Update PN.	2020.08
A4	Add 512G PN.	2020.03
A3	Update endurance.	2020.03
A2	Add 128GB capacity, update power consumption.	2019.12
A1	Add 256GB capacity.	2019.10
A0	Initial release.	2019.07

Table of content

1. General Description	4
2. Mechanical Specification	5
2.1 M.2 2280 SSD physical dimensions and Weight	5
3. Product Specifications	6
3.1 System Interface and Configuration	6
3.2 System Performance	6
3.3 Drive Capacity	6
3.4 Supply Voltage	6
3.5 System Power Consumption	7
3.6 System Reliability	7
3.7 Endurance	7
3.8 Environmental Specifications	8
4. Electrical Interface Specification	8
4.1 M.2 2280 Pin Assignments	8
5. Command Descriptions	10
5.1 Supported ATA Commands	10
5.2 SMART Attributes	11
6. Identify Device Data	12
7. Product Line up	24
7.1 SATA3 M.2 2280	24
8. Contact information	24

1. General Description

The FORESEE SSD (Solid State Drive) fully consists of semiconductor devices using NAND Flash Memory which provide high reliability and high performance for a storage media. The SSD doesn't have any moving parts such as platter (disk) and head media, which provides a better solution in a notebook PC, Tablet PC and industrial PC for a storage device providing higher performance, reduced latencies, and a low power consumption in a small form factor. SSD has the same host interface with Hard Disk Drives and has a same physical dimension.

●Capacity

- 128/256/512GB is available

●Form Factor

- M.2 2280

●Host interface

- Serial ATA interface of 6.0Gbps
- Complies with ATA/ATAPI-8
- Supports NCQ
- Supports TRIM

●Performance

- 128GB
 - Read: Up to 525MB/s
 - Write: Up to 365MB/s
- 256GB
 - Read: Up to 525MB/s
 - Write: Up to 465MB/s
- 512GB
 - Read: Up to 545MB/s
 - Write: Up to 485MB/s

●Power Consumption

- Active write:1200mW (512GB)
- Active read: 1160mW (512GB)

●Temperature

- Operating : 0°C to 70°C

●Shock

- Shock : 1500G, duration 0.5ms, Half Sine Wave
- Vibration : 7~800Hz, 3.08Grms, 30min/axis(X,Y,Z)
- * Applicable only for cased product

●MTBF

- 1,500,000 Hours

●Weight

- 128/256/512GB
- Max 9g

●SSD Functional Block Diagram

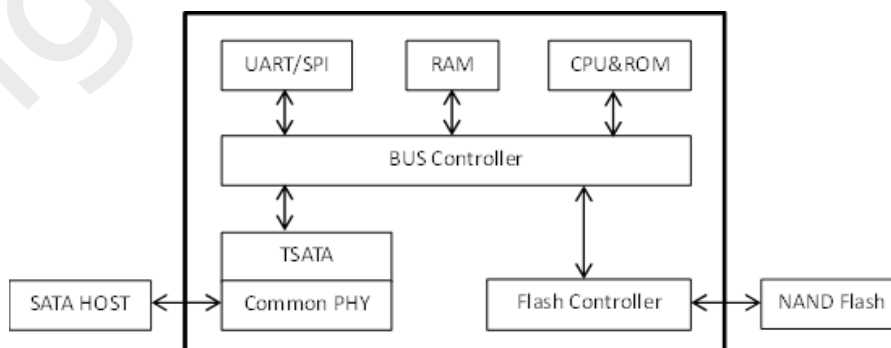

[Figure 1-1] SSD Functional Block Diagram

2. Mechanical Specification

2.1 M.2 2280 SSD physical dimensions and Weight

Capacity(GB)	Height (mm)	Width (mm)	Length (mm)	Weight (gram)
128/256/512	MAX 2.25	22.00±0.15	80.00±0.15	MAX 9g

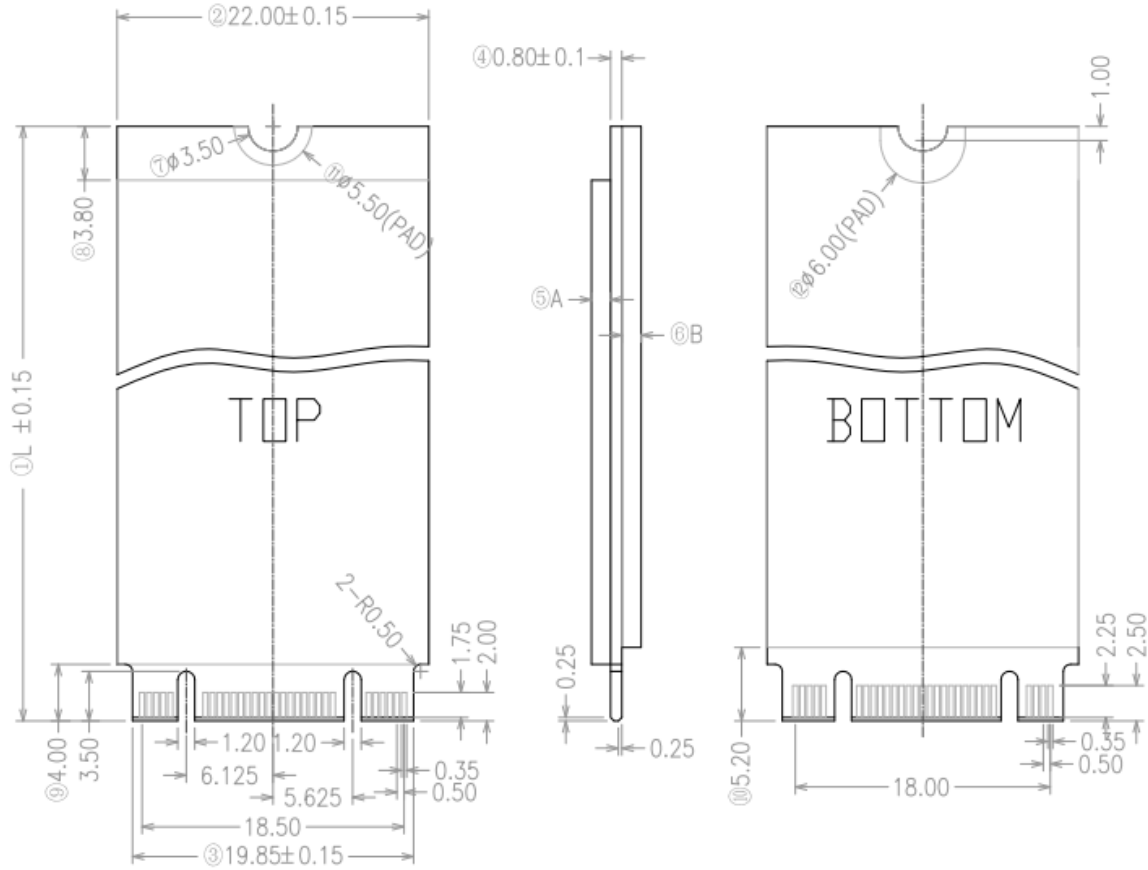

L	A (MAX)	B (MAX)
80	1.35	0

[Figure 2-1] M.2 2280 Physical dimension

3. Product Specifications

3.1 System Interface and Configuration

Burst read/write rate is 600 MB/sec (6.0 Gb/sec).

3.2 System Performance

SATA 6Gb/s host interface				
Parameter	Unit	128GB	256GB	512GB
Sequential Read (Max)	MB/S	525	525	545
Sequential Write (Max)	MB/S	365	465	485
Random Read (4K) QD=32 (Max)	IOPS	38140	42750	52000
Random Write (4K) QD=32 (Max)	IOPS	52470	52480	57000

* Actual performance may vary depending on use conditions and environment

* Note

1. Performance measured using CrystalDiskMark 5.1.0 x64
2. Write cache enabled
3. 1MB/sec = 1,048,576 bytes/sec was used in sequential performance
 - System: Intel Z170 Chipset, Intel Core i5-6600K@3.5GHz, 4GB DDR4
 - OS: Windows 7 x64

3.3 Drive Capacity

Nominal Capacity	128GB	256GB	512GB
Unformatted Capacity	119.24GB	238.47GB	476.94GB
User-Addressable Sectors	250069680	500118192	1000215216
Bytes per Sector	512 Bytes		

NOTE:

1 Megabyte (MB) = 1 Million bytes; 1 Gigabyte (GB) = 1 Billion bytes

*Actual usable capacity may be less (due to formatting, partitioning, operating system, applications or otherwise)

3.4 Supply Voltage

Item	Requirements
Allowable voltage	3.3V ± 5%
Allowable noise/ripple	100mV p-p or less

3.5 System Power Consumption

Input Voltage 3.3V±5%			
Parameter	128GB	256GB	512GB
Sequential Read	1100 mW	1150 mW	1160 mW
Sequential Write	1030 mW	1250 mW	1260 mW
Random Read	760 mW	850 mW	860 mW
Random Write	630 mW	780 mW	795 mW
Idle	350 mW	350 mW	360 mW
Devslp	3.3 mW	3.5 mW	7.6 mW

CPU : Intel Core i5-6600K

DRAM : 4GB DDR4

Chipset : Intel Z170

OS : Windows 7 x64

Test Tool : IO Meter 2006

3.6 System Reliability

MTBF	1,500,000 Hours
-------------	-----------------

MTBF is Mean Time Between Failure. As same word, annual failure ratio is 0.4%.

3.7 Endurance

TBW		
128GB	256GB	512GB
192TB	384TB	768TB

Notes:

1-TBW (Terabytes Written) is a measurement of SSDs' expected lifespan, which represents the amount of data written to the device. To calculate the TBW of a SSD, the following equation is applied:

$$TBW = [(NAND\ Endurance) \times (SSD\ Capacity)] / WAF$$

NAND Endurance: NAND endurance refers to the P/E (Program/Erase) cycle of a NAND flash.

SSD Capacity: The SSD capacity is the specific capacity in total of a SSD.

WAF: Write Amplification Factor (WAF) is a numerical value representing the ratio between the amount of data that a SSD controller needs to write and the amount of data that the host's flash controller writes. A better WAF, which is near 1, guarantees better endurance and lower frequency of data written to flash memory.

2-The above TBW values are calculated based on WAF=1.

3-TBW may differ according to flash configuration and platform.

4-The endurance of SSD could be estimated based on user behavior, NAND endurance cycles, and write amplification factor. It is not guaranteed by flash vendor.

3.8 Environmental Specifications

Features	Operating	Non-Operating
Temperature	0°C to 70°C	-40°C to 85°C
Humidity	5% to 95%, non-condensing	
Vibration	7~800Hz, 3.08Grms, 30min/axis(X,Y,Z)	
Shock	1500G, duration 0.5ms, Half Sine Wave	

Notes:

1-Temperature is measured by SMART Temperature .Proper airflow recommended.

2-Humidity is measured in non-condensing.

3-Test condition for shock: 0.5ms duration with half sine wave.

4-Test condition for vibration: 10Hz to 2,000Hz, 15mins/axis on 3axis.

4. Electrical Interface Specification

4.1 M.2 2280 Pin Assignments

Pin #	Type	Description	Pin #	Type	Description
1	GND	Ground	2	3.3V	Supply pin, 3.3V +/- 5% @ 0.5 Amps
3	GND	Ground	4	3.3V	Supply pin, 3.3V +/- 5% @ 0.5 Amps
5	GND	Ground	6	no connect	
7	no connect		8	no connect	
9	no connect		10	DAS/DSS	Device Activity / Disable Staggered Spin-up
11	no connect		12	no connect	
13	no connect		14	no connect	
15	no connect		16	no connect	
17	no connect		18	no connect	
19	no connect		20	no connect	
21	no connect		22	no connect	
23	no connect		24	no connect	
25	no connect		26	no connect	
27	GND	Ground	28	no connect	
29	no connect		30	no connect	
31	no connect		32	no connect	
33	GND	Ground	34	no connect	
35	no connect		36	no connect	
37	no connect		38	DEVSLP	0 / 1.8V DEVSLP (device sleep mode) enable.
39	GND	Ground	40	no connect	

41	SATA-B+	Host receiver differential signal pair	42	no connect	
43	SATA-B-	Host receiver differential signal pair	44	no connect	
45	GND		46	no connect	
47	SATA-A-	Host transmitter differential signal pair	48	no connect	
49	SATA-A+	Host transmitter differential signal pair	50	no connect	
51	GND	Ground	52	no connect	
53	no connect		54	no connect	
55	no connect		56	no connect	
57	GND	Ground	58	no connect	
59	no connect		60	no connect	
61	no connect		62	no connect	
63	no connect		64	no connect	
65	no connect		66	no connect	
67	no connect		68	no connect	
69	GND	Ground	70	3.3V	Supply pin, 3.3V +/- 5% @ 0.5 Amps
71	GND	Ground	72	3.3V	Supply pin, 3.3V +/- 5% @ 0.5 Amps
73	GND	Ground	74	3.3V	Supply pin, 3.3V +/- 5% @ 0.5 Amps
75	GND	Ground			

Table 4-1: M.2 2280 Connector Pin Assignment

5. Command Descriptions

5.1 Supported ATA Commands

Command	Code	Protocol
General Feature Set		
Execute Device Diagnostic	90h	Execute device diagnostic
Flush Cache	E7h	Non-data
Identify Device	ECh	PIO data-in
Initialize Drive Parameters	91h	Non-data
Read DMA	C8h	DMA
Read Multiple	C4h	PIO data-in
Read Sector(s)	20h	PIO data-in
Read Verify Sector(s)	40h or 41h	Non-data
Set Feature	EFh	Non-data
Set Multiple Mode	C6h	Non-data
Write DMA	CAh	DMA
Write Multiple	C5h	PIO data-out
Write Sector(s)	30h	PIO data-out
NOP	00h	Non-data
Read Buffer	E4h	PIO data-in
Write Buffer	E8h	PIO data-out
Power Management Feature Set		
Check Power Mode	E5h or 98h	Non-data
Idle	E3h or 97h	Non-data
Idle Immediate	E1h or 95h	Non-data
Sleep	E6h or 99h	Non-data
Standby	E2h or 96h	Non-data
Standby Immediate	E0h or 94h	Non-data
SMART Feature Set		
SMART Read Data	B0h	PIO data-in
SMART Read Threshold	B0h	PIO data-in
Host Protected Area Feature Set		
Read Native Max Address	F8h	Non-data
48-bit Address Feature Set		
Flush Cache Ext	EAh	Non-data
Read Sector(s) Ext	24h	PIO data-in
Read DMA Ext	25h	DMA
Read Multiple Ext	29h	PIO data-in
Read Native Max Address Ext	27h	Non-data
Read Verify Sector(s) Ext	42h	Non-data
Write DMA Ext	35h	DMA

Write Multiple Ext	39h	PIO data-out
Write Sector(s) Ext	34h	PIO data-out
NCQ Feature Set		
Read FPDMA Queued	60h	DMA Queued
Write FPDMA Queued	61h	DMA Queued
Others		
Data Set Management	06h	DMA
Seek	70h	Non-data

5.2 SMART Attributes

The following table defines the vendor specific data in byte 2 to 361 of the 512-byte SMART data.

SMART Data Vendor-specific Attributes

Attribute ID (hex)	Attribute Name
05	Number of New Bad Block
09	Power On Hours
0C	Power Cycle Count
A1	Reserved
A4	Total Erase Count
A5	Max Erase Count
A6	Min Erase Count
A7	Average Erase Count
C0	Power off Retract Count
C2	Controlled temperature
C3	Reserved
B0	Reserved
B1	Reserved
B2	Reserved
C7	SATA CRC Error Count
F1	Total LBAs Written (each write unit = 1GB)
F2	Total LBAs Read (each read unit = 1GB)
F3	Reserved
F4	Reserved
FA	Reserved
FB	Reserved
FC	Reserved
FD	Reserved
FE	Reserved

6. Identify Device Data

The Identify Device command enables the host to receive parameter information from the SSD. This command has the same protocol as the Read Sector(s) command. The parameter words in the buffer have the arrangement and meanings defined in the following table.

ID Table Information

Word	Default Value	Description
0	045Ah	General configuration 15 0=ATA device 14:8 Retired 7:6 Obsolete 5:3 Retired 2 Response incomplete 1 Retired 0 Reserved
1	3FFFh	Obsolete
2	C837h	Specific configuration
3	0010h	Obsolete
4 - 5	00000000h	Retired
6	003Fh	Obsolete
7 - 8	00000000h	Reserved for the CompactFlash Association
9	0000h	Retired
10 - 19	X..Xh	Serial number in ASCII (Right justified)
20 - 21	00000000h	Retired
22	0000h	Obsolete
23 - 26	X..Xh	Firmware revision in ASCII
27 - 46	X..Xh	Model number in ASCII (Left justified) Big Endian Byte Order in Word
47	8001h	15:8 80h 7:0 01h=Maximum number of logical sectors that shall be DRQ data block on READ/WRITE MULTIPLE commands
48	4000h	Trusted Computing feature set options 15 Shall be cleared to zero 14 Shall be set to one 13:1 Reserved for the Trusted Computing Group 0 1=Trusted Computing feature set is supported

49	2F00h	<p>Capabilities</p> <p>15:14 Reserved for the IDENTIFY PACKET DEVICE command.</p> <p>13 1 = Standby timer values as specified in this standard are supported</p> <p>0 = Standby timer values shall be managed by the device</p> <p>12 Reserved for the IDENTIFY PACKET DEVICE command.</p> <p>11 1 = IORDY supported</p> <p>0 = IORDY may be supported</p> <p>10 1 = IORDY may be disabled</p> <p>9 Shall be set to one to indicate that LBA is supported.</p> <p>8 1 = DMA supported</p> <p>7:2 Reserved</p> <p>1:0 Current Long Physical Sector Alignment setting</p>
50	4000h	<p>Capabilities</p> <p>15 Shall be cleared to zero</p> <p>14 Shall be set to one</p> <p>13:2 Reserved</p> <p>1 Obsolete</p> <p>0 Shall be set to one to indicate a vendor specific Standby timer value minimum</p>
51 - 52	00000000h	Obsolete
53	0007h	<p>15:8 Free-fall Control Sensitivity</p> <p>00h = Vendor's recommended setting</p> <p>01h-FFh = Sensitivity level. A larger number is a more sensitive setting.</p> <p>7:3 Reserved</p> <p>2 1 = the fields reported in word 88 are valid</p> <p>0 = the fields reported in word 88 are not valid</p> <p>1 1 = the fields reported in words (70:64) are valid</p> <p>0 = the fields reported in words (70:64) are not valid</p> <p>X 0 Obsolete</p>
54 - 58	X..Xh	Obsolete
59	0000h	<p>15 1 = The BLOCK ERASE EXT command is supported</p> <p>14 1 = The OVERWRITE EXT command is supported</p> <p>13 1 = The CRYPTO SCRAMBLE EXT command is supported</p> <p>12 1 = The Sanitize feature set is supported</p> <p>11:9 Reserved</p> <p>8 1 = Multiple logical sector setting is valid</p> <p>7:0 Current setting for number of logical sectors that shall be transferred per DRQ data block on READ/WRITE Multiple commands</p>
60 - 61	X..Xh	Total number of user addressable logical sectors for 28-bit commands (DWord)
62	0000h	Obsolete

63	0007h	<p>15:11 Reserved</p> <p>10 1 = Multiword DMA mode 2 is selected 0 = Multiword DMA mode 2 is not selected</p> <p>9 1 = Multiword DMA mode 1 is selected 0 = Multiword DMA mode 1 is not selected</p> <p>8 1 = Multiword DMA mode 0 is selected 0 = Multiword DMA mode 0 is not selected</p> <p>7:3 Reserved</p> <p>2 1 = Multiword DMA mode 2 and below are supported 1 1 = Multiword DMA mode 1 and below are supported 0 1 = Multiword DMA mode 0 is supported</p>
64	0003h	<p>15:8 Reserved</p> <p>7:0 PIO modes supported</p>
65	0078h	<p>Minimum Multiword DMA transfer cycle time per word</p> <p>15:0 Cycle time in nanoseconds</p>
66	0078h	<p>Manufacturer's recommended Multiword DMA transfer cycle time</p> <p>15:0 Cycle time in nanoseconds</p>
67	0078h	<p>Minimum PIO transfer cycle time without flow control</p> <p>15:0 Cycle time in nanoseconds</p>
68	0078h	<p>Minimum PIO transfer cycle time with IORDY flow control</p> <p>15:0 Cycle time in nanoseconds</p>
69	4C20h	<p>Additional Supported</p> <p>15 1 = CFAST Specification Support</p> <p>14 1 = Deterministic read after Trim is supported</p> <p>13 1 = Long Physical Sector Alignment Error Reporting Control is supported</p> <p>12 1 = DEVICE CONFIGURATION IDENTIFY DMA and DEVICE CONFIGURATIONSET DMA are supported</p> <p>11 1 = READ BUFFER DMA is supported</p> <p>10 1 = WRITE BUFFER DMA is supported</p> <p>9 1 = SET MAX SET PASSWORD DMA and SET MAX UNLOCK DMA are supported</p> <p>8 1 = DOWNLOAD MICROCODE DMA is supported</p> <p>7 Reserved for IEEE-1667</p> <p>6 0 = Optional ATA device 28-bit commands supported</p> <p>5 1 = Read zero after Trim is supported</p> <p>4:0 Reserved</p>
70	0000h	Reserved
71 - 74	X..Xh	Reserved for the IDENTIFY PACKET DEVICE command
75	001Fh	<p>Queue depth</p> <p>15:5 Reserved</p> <p>4:0 Maximum queue depth - 1</p>

76	E10Eh	<p>Serial ATA Capabilities</p> <p>15:13 Reserved for Serial ATA</p> <p>12 1 = Supports NCQ priority information</p> <p>11 1 = Supports Unload while NCQ commands are outstanding</p> <p>10 1 = Supports Phy Event Counters</p> <p>9 1 = Supports receipt of host initiated power management requests</p> <p>8 1 = Supports the NCQ feature set</p> <p>7:3 Reserved for Serial ATA</p> <p>2 1 = Supports SATA Gen2 Signaling Speed (3.0Gb/s)</p> <p>1 1 = Supports SATA Gen1 Signaling Speed (1.5Gb/s)</p> <p>0 Shall be cleared to zero</p>
77	00C6h	Reserved for Serial ATA
78	0104h	<p>Serial ATA features supported</p> <p>15:7 Reserved for Serial ATA</p> <p>6 1 = Device supports Software Settings Preservation</p> <p>5 Reserved for Serial ATA</p> <p>4 1 = Device supports in-order data delivery</p> <p>3 1 = Device supports initiating power management</p> <p>2 1 = Device supports DMA Setup auto-activation</p> <p>1 1 = Device supports non-zero buffer offsets</p> <p>0 Shall be cleared to zero</p>
79	00C4h	<p>Serial ATA features enabled</p> <p>15:7 Reserved for Serial ATA</p> <p>6 1 = Software Settings Preservation enabled</p> <p>5 Reserved for Serial ATA</p> <p>4 1 = In-order data delivery enabled</p> <p>3 1 = Device initiated power management enabled</p> <p>2 1 = DMA Setup auto-activation enabled</p> <p>1 1 = Non-zero buffer offsets enabled</p> <p>0 Shall be cleared to zero</p>
80	07F8h	<p>Major version number</p> <p>15:9 Reserved</p> <p>8 1 = supports ATA8-ACS</p> <p>7 1 = supports ATA/ATAPI-7</p> <p>6 1 = supports ATA/ATAPI-6</p> <p>5 1 = supports ATA/ATAPI-5</p> <p>4 1 = supports ATA/ATAPI-4</p> <p>3 Obsolete</p> <p>2 Obsolete</p> <p>1 Obsolete</p> <p>0 Reserved</p>
81	011Bh	Minor version number

<p>82</p>	<p>7069h</p>	<p>Commands and feature sets supported</p> <p>15 Obsolete</p> <p>14 1 = The NOP command is supported</p> <p>13 1 = The READ BUFFER command is supported</p> <p>12 1 = The WRITE BUFFER command is supported</p> <p>11 Obsolete</p> <p>10 1 = The HPA feature set is supported</p> <p>9 Shall be cleared to zero to indicate that the DEVICE RESET command is not supported</p> <p>8 1 = The SERVICE interrupt is supported</p> <p>7 1 = The release interrupt is supported</p> <p>6 1 = Read look-ahead is supported</p> <p>5 1 = The volatile write cache is supported</p> <p>4 Shall be cleared to zero to indicate that the PACKET feature set is not supported</p> <p>3 Shall be set to one to indicate that the mandatory Power Management feature set is supported</p> <p>2 Obsolete</p> <p>1 1 = The Security feature set is supported</p> <p>0 1 = The SMART feature set is supported</p>
<p>83</p>	<p>7409h</p>	<p>Commands and feature sets supported</p> <p>15 Shall be cleared to zero</p> <p>14 Shall be set to one</p> <p>13 1 = The FLUSH CACHE EXT command is supported</p> <p>12 Shall be set to one to indicate that the mandatory FLUSH CACHE command is supported</p> <p>11 1 = The DCO feature set is supported</p> <p>10 1 = The 48-bit Address feature set is supported</p> <p>9 1 = The AAM feature set is supported</p> <p>8 1 = The SET MAX security extension is supported</p> <p>7 Reserved for the Address Offset Reserved Area Boot Method</p> <p>6 1 = SET FEATURES subcommand is required to spin-up after power-up</p> <p>5 1 = The PUIS feature set is supported</p> <p>4 Obsolete</p> <p>3 1 = The APM feature set is supported</p> <p>2 1 = The CFA feature set is supported</p> <p>X 1 Obsolete</p> <p>0 1 = The DOWNLOAD MICROCODE command is supported</p>

<p>84</p>	<p>4160h</p>	<p>Commands and feature sets supported</p> <p>15 Shall be cleared to zero</p> <p>14 Shall be set to one</p> <p>13 1 = The IDLE IMMEDIATE command with UNLOAD feature is supported</p> <p>12 Reserved for TLC</p> <p>11 Reserved for TLC</p> <p>10:9 Obsolete</p> <p>8 1 = The 64-bit World wide name is supported</p> <p>7 Obsolete</p> <p>6 1 = The WRITE DMA FUA EXT and WRITE MULTIPLE FUA EXT commands are supported</p> <p>5 1 = The GPL feature set is supported</p> <p>4 1 = The Streaming feature set is supported</p> <p>3 1 = The Media Card Pass Through Command feature set is supported</p> <p>2 1 = Media serial number is supported</p> <p>1 1 = The SMART self-test is supported</p> <p>0 1 = SMART error logging is supported</p>
<p>85</p>	<p>0769h</p>	<p>Commands and feature sets supported or enabled</p> <p>15 Obsolete</p> <p>14 1 = The NOP command is supported</p> <p>13 1 = The READ BUFFER command is supported</p> <p>12 1 = The WRITE BUFFER command is supported</p> <p>11 Obsolete</p> <p>10 1 = HPA feature set is supported</p> <p>9 Shall be cleared to zero to indicate that the DEVICE RESET command is not supported</p> <p>8 1 = The SERVICE interrupt is enabled</p> <p>7 1 = The release interrupt is enabled</p> <p>6 1 = Read look-ahead is enabled</p> <p>5 1 = The volatile write cache is enabled</p> <p>4 Shall be cleared to zero to indicate that the PACKET feature set is not supported</p> <p>3 Shall be set to one to indicate that the mandatory Power Management feature set is supported</p> <p>2 Obsolete</p> <p>1 1 = The Security feature set is enabled</p> <p>0 1 = The SMART feature set is enabled</p>

86	B409h	<p>Commands and feature sets supported or enabled</p> <p>15 1 = Words 119..120 are valid</p> <p>14 Reserved</p> <p>13 1 = FLUSH CACHE EXT command supported</p> <p>12 1 = FLUSH CACHE command supported</p> <p>11 1 = The DCO feature set is supported</p> <p>10 1 = The 48-bit Address features set is supported</p> <p>9 1 = The AAM feature set is enabled</p> <p>8 1 = the SET MAX security extension is enabled by SET MAX SET PASSWORD</p> <p>7 Reserved for Address Offset Reserved Area Boot Method</p> <p>6 1 = SET FEATURES subcommand is required to spin-up after power-up</p> <p>5 1 = The PUIS feature set is enabled</p> <p>4 Obsolete</p> <p>3 1 = The APM feature set is enabled</p> <p>2 1 = The CFA feature set is supported</p> <p>1 Obsolete</p> <p>0 1 = The DOWNLOAD MICROCODE command is supported</p>
87	4160h	<p>Commands and feature sets supported or enabled</p> <p>15 Shall be cleared to zero</p> <p>14 Shall be set to one</p> <p>13 1 = The IDLE IMMEDIATE command with UNLOAD FEATURE is supported</p> <p>12 Reserved for TLC</p> <p>11 Reserved for TLC</p> <p>10:9 Obsolete</p> <p>8 1 = The 64-bit World wide name is supported</p> <p>7 Obsolete</p> <p>6 1 = The WRITE DMA FUA EXT and WRITE MULTIPLE FUA EXT commands are supported</p> <p>5 1 = The GPL feature set is supported</p> <p>4 Obsolete</p> <p>3 1 = The Media Card Pass Through Command feature set is supported</p> <p>2 1 = Media serial number is valid</p> <p>1 1 = SMART self-test supported</p> <p>0 1 = SMART error logging is supported</p>
88	407Fh	<p>Ultra DMA modes</p> <p>15 Reserved</p> <p>14 1 = Ultra DMA mode 6 is selected 0 = Ultra DMA mode 6 is not selected</p> <p>13 1 = Ultra DMA mode 5 is selected 0 = Ultra DMA mode 5 is not selected</p> <p>12 1 = Ultra DMA mode 4 is selected 0 = Ultra DMA mode 4 is not selected</p>

		<p>11 1 = Ultra DMA mode 3 is selected 0 = Ultra DMA mode 3 is not selected</p> <p>10 1 = Ultra DMA mode 2 is selected 0 = Ultra DMA mode 2 is not selected</p> <p>9 1 = Ultra DMA mode 1 is selected 0 = Ultra DMA mode 1 is not selected</p> <p>8 1 = Ultra DMA mode 0 is selected 0 = Ultra DMA mode 0 is not selected</p> <p>7 Reserved</p> <p>6 1 = Ultra DMA mode 6 and below are supported</p> <p>5 1 = Ultra DMA mode 5 and below are supported</p> <p>4 1 = Ultra DMA mode 4 and below are supported</p> <p>3 1 = Ultra DMA mode 3 and below are supported</p> <p>2 1 = Ultra DMA mode 2 and below are supported</p> <p>1 1 = Ultra DMA mode 1 and below are supported</p> <p>0 1 = Ultra DMA mode 0 is supported</p>
89	0005h	<p>15:8 Reserved</p> <p>7:0 Time required for Normal Erase mode SECURITY ERASE UNIT command</p>
90	0005h	<p>15:8 Reserved</p> <p>7:0 Time required for an Enhanced Erase mode SECURITY ERASE UNIT command</p>
91	00FEh	Current APM level value
92	0000h	Master Password Identifier
93	0000h	<p>Hardware reset result</p> <p>15 Shall be cleared to zero.</p> <p>14 Shall be set to one.</p> <p>13 1 = device detected CBLID- above ViHB 0 = device detected CBLID- below ViLB</p> <p>12:8 Device 1 hardware reset result.</p> <p>Device 0 shall clear these bits to zero.</p> <p>Device 1 shall set these bits as follows:</p> <p>12 Reserved.</p> <p>11 0 = Device 1 did not assert PDIAG-. 1 = Device 1 asserted PDIAG-.</p> <p>10:9 These bits indicate how Device 1 determined the device number:</p> <p>00 = Reserved.</p> <p>01 = a jumper was used.</p> <p>10 = the CSEL signal was used.</p> <p>11 = some other method was used or the method is unknown. 8 Shall be set to one.</p> <p>7:0 Device 0 hardware reset result.</p> <p>Device 1 shall clear these bits to zero.</p> <p>Device 0 shall set these bits as follows:</p> <p>7 Reserved.</p>

		<p>6 0 = Device 0 does not respond when Device 1 is selected. 1 = Device 0 responds when Device 1 is selected. 5 0 = Device 0 did not detect the assertion of DASP-. 1 = Device 0 detected the assertion of DASP-. 4 0 = Device 0 did not detect the assertion of PDIAG-. 3 0 = Device 0 failed diagnostics. 1 = Device 0 passed diagnostics. 2:1 These bits indicate how Device 0 determined the device number: 00 = Reserved. 01 = a jumper was used. 10 = the CSEL signal was used. 11 = some other method was used or the method is unknown. 0 Shall be set to one.</p>
94	0000h	<p>Current AAM value 15:8 Vendor's recommended AAM value. 7:0 Current AAM value.</p>
95	0000h	Stream Minimum Request Size
96	0000h	Streaming Transfer Time - DMA
97	0000h	Streaming Access Latency - DMA and PIO
98 - 99	00000000h	Streaming Performance Granularity (DWord)
100 - 103	X..Xh	Total Number of User Addressable Logical Sectors for 48-bit commands (QWord)
104	0000h	Streaming Transfer Time - PIO
105	0008h	Maximum number of 512-byte blocks of LBA Range Entries per DATA SET MANAGEMENT command
106	4000h	<p>Physical sector size / logical sector size 15 Shall be cleared to zero 14 Shall be set to one 13 1 = Device has multiple logical sectors per physical sector. 12 1 = Device Logical Sector longer than 256 Words 11:4 Reserved 3:0 2XP logical sectors per physical sector</p>
107	0000h	Inter-seek delay for ISO 7779 standard acoustic testing
108 - 111	X..Xh	World wide name
112 - 115	X..Xh	Reserved
116	0000h	Reserved for TLC
117 - 118	00000000h	Logical sector size (DWord)
119	401Ch	<p>Commands and feature sets supported (Continued from words 82..84) 15 Shall be cleared to zero 14 Shall be set to one 13:8 Reserved 7 1 = Extended Power Conditions feature set is supported</p>

		<p>6 1 = Extended Status Reporting feature set is supported</p> <p>5 1 = The Free-fall Control feature set is supported</p> <p>4 1 = The DOWNLOAD MICROCODE command with mode 3 is supported</p> <p>3 1 = The READ LOG DMA EXT and WRITE LOG DMA EXT commands are supported</p> <p>2 1 = The WRITE UNCORRECTABLE EXT command is supported</p> <p>1 1 = The Write-Read-Verify feature set is supported</p> <p>0 Reserved for DDT</p>
120	401Ch	<p>Commands and feature sets supported or enabled (Continued from words 85..87)</p> <p>15 Shall be cleared to zero</p> <p>14 Shall be set to one</p> <p>13:8 Reserved</p> <p>7 1 = At least one Extended Power Conditions Idle timer is enabled</p> <p>6 1 = Extended Status Reporting feature set is enabled</p> <p>5 1 = The Free-fall Control feature set is enabled</p> <p>4 1 = The DOWNLOAD MICROCODE command with mode 3 is supported</p> <p>3 1 = The READ LOG DMA EXT and WRITE LOG DMA EXT commands are supported</p> <p>2 1 = The WRITE UNCORRECTABLE EXT command is supported</p> <p>1 1 = The Write-Read-Verify feature set is enabled</p> <p>0 Reserved for DDT</p>
121 - 126	X..Xh	Reserved for expanded supported and enabled settings
127	0000h	Obsolete
128	0000h	<p>Security status</p> <p>15:9 Reserved</p> <p>8 Master Password Capability: 0 = High, 1 = Maximum</p> <p>7:6 Reserved</p> <p>5 1 = Enhanced security erase supported</p> <p>4 1 = Security count expired</p> <p>3 1 = Security frozen</p> <p>2 1 = Security locked</p> <p>1 1 = Security enabled</p> <p>0 1 = Security supported</p>
129 - 159	X..Xh	Vendor specific
160	0000h	<p>CFA power mode</p> <p>15 Word 160 supported</p> <p>14 Reserved</p> <p>13 CFA power mode 1 is required for one or more commands implemented by the device</p> <p>12 CFA power mode 1 disabled</p> <p>11:0 Maximum current in ma</p>
161 - 167	X..Xh	Reserved for the CompactFlash Association

168	0000h	15:4 Reserved 3:0 Device Nominal Form Factor
169	0001h	DATA SET MANAGEMENT is supported 15:1 Reserved 0 1 = the Trim bit in the DATA SET MANAGEMENT is supported
170 - 173	X..Xh	Additional Product Identifier (ATA String)
174 - 175	X..Xh	Reserved
176 - 205	X..Xh	Current media serial number (ATA string)
206	0000h	SCT Command Transport 15:12 Vendor Specific 11:6 Reserved 5 The SCT Data Tables command is supported 4 The SCT Feature Control command is supported 3 The SCT Error Recovery Control command is supported 2 The SCT Write Same command is supported 1 Obsolete 0 The SCT Command Transport is supported
207 - 208	00000000h	Reserved for CE-ATA.
209	4000h	Alignment of logical blocks within a physical block 15 Shall be cleared to zero 14 Shall be set to one 13:0 Logical sector offset within the first physical sector where the first logical sector is placed
210 - 211	00000000h	Write-Read-Verify Sector Count Mode 3 (DWord)
212 - 213	00000000h	Write-Read-Verify Sector Count Mode 2 (DWord)
214	0000h	NV Cache Capabilities 15:12 NV Cache feature set version 11:8 NV Cache Power Mode feature set version 7:5 Reserved 4 1 = NV Cache feature set enabled 3:2 Reserved 1 1 = NV Cache Power Mode feature set enabled 0 1 = NV Cache Power Mode feature set supported
215 - 216	00000000h	NV Cache Size in Logical Blocks (DWord)
217	0001h	Nominal media rotation rate
218	0000h	Reserved
219	0000h	NV Cache Options 15:8 Reserved 7:0 Device Estimated Time to Spin Up in Seconds
220	0000h	15:8 Reserved 7:0 Write-Read-Verify feature set current mode
221	0000h	Reserved

222	10FFh	Transport major version number 0000h or FFFFh = device does not report version 15:12 Transport Type 0h = Parallel 1h = Serial 2h-Fh = Reserved Parallel Serial 11:6 Reserved Reserved 5 Reserved SATA Rev 3.0 4 Reserved SATA Rev 2.6 3 Reserved SATA Rev 2.5 2 Reserved SATA II: Extensions 1 ATA/ATAPI-7 SATA 1.0a 0 ATA8-APT ATA8-AST
223	0000h	Transport minor version number
224 - 233	X..Xh	Reserved
234	0008h	Minimum number of 512-byte data blocks per DOWNLOAD MICROCODE command for mode 03h
235	0400h	Maximum number of 512-byte data blocks per DOWNLOAD MICROCODE command for mode 03h
236 - 254	X..Xh	Reserved
255	XXXXh	Integrity word 15:8 Checksum 7:0 Checksum Validity Indicator

Notes:

X = content (byte) is vendor specific and may be fixed or variable.

7. Product Line up

7.1 SATA3 M.2 2280

Type	Capacity	MODEL	Part Number
SATA3 M.2 2280 SSD	128GB	S41CF128G	FSGGCLC-128G
SATA3 M.2 2280 SSD	256GB	S41CF256G	FSGGCLC-256G FSGGCOC-256G
SATA3 M.2 2280 SSD	512GB	S41CF512G	FSGGCLC-512G FSGGCOC-512G

8. Contact information

Tel: +86-755-8616-8848

Fax: +86-755-8616-9388

Email: sales@longsys.com

Website: www.longsys.com

Add: 8/F, 1 Building, Finance Base, No.8, Kefa Road, High-Tech Park, Shenzhen, China