

FORESEE PCIe Gen3 M.2 2280 SSD P78A Datasheet

Version: A4

2020.07

Shenzhen Longsys Electronics Co., Ltd, together with any and all of its affiliates (herein after referred as "Longsys" or "Longsys Electronics") LONGSYS RESERVES THE RIGHT TO CHANGE PRODUCTS, INFORMATION AND SPECIFICATIONS WITHOUT NOTICE.

Products and specifications discussed herein are for reference purposes only. All information discussed herein is provided on an "AS IS" basis, without warranties of any kind.

This document and all information discussed herein remain the sole and exclusive property of Longsys. No license of any patent, copyright, mask work, trademark or any other intellectual property right is granted by one party to the other party under this document, by implication, estoppel or otherwise.

Longsys products are not intended for use in life support, critical care, medical, safety equipment, or similar applications where product failure could result in loss of life or personal or physical harm, or any military or defense application, or any governmental procurement to which special terms or provisions may apply.

For updates or additional information about Longsys products, contact your nearest Longsys office.

All brand names, trademarks and registered trademarks belong to their respective owners.

© 2018 Shenzhen Longsys Electronics Co., Ltd. All rights reserved.

Revision History

Revision Number	Description	Revision Date
A4	Add TBW info	2020.07
A3	Update power consumption.	2020.06
A2	Update PN.	2020.05
A1	Update performance.	2020.04
A0	Initial release.	2020.04

Table of content

1. General Description	4
2. Mechanical Specification	5
2.1 M.2 2280 SSD physical dimensions and Weight	5
3. Product Specifications	6
3.1 Capacity	6
3.2 Performance	6
3.3 System Power Consumption	6
3.4 Supply Voltage	7
3.5 System Reliability	7
3.6 Endurance	7
3.7 Environmental Specifications	7
4. Electrical Interface Specification	8
4.1 Connector Dimension and Pin Location	8
4.2 M.2 2280 Pin Assignments and Definition	8
5. Supported Command Set and Feature	9
5.1 Admin Command Set	9
5.2 NVM Express I/O Command Set	9
5.3 Log Page Identifiers Support	10
5.4 Feature Identifiers Support	10
5.5 SMART/Health Information	10
5.6 Identify Command	11
6. Product Line up	16
7. Contact information	16

1. General Description

●Capacity

– 256/512GB/1TB is available

●Form Factor

– M.2 2280

●Features

- PCIe Gen3 8Gb/s Interface, up to 4 Lanes
- Compliant with NVMe Express Revision 1.3
- Support Host Memory Buffer
- Support ASPM L1.2 Mode

●Performance

- 256GB
- Read: Up to 1900MB/s
- Write: Up to 1100MB/s
- 512GB
- Read: Up to 2000MB/s
- Write: Up to 1500MB/s
- 1TB
- Read: Up to 2000MB/s
- Write: Up to 1800MB/s

●Power Consumption

- Active write: 3500mW (1TB)
- Active read: 3500mW (1TB)

●Temperature

– Operating : 0°C to 70°C

●Shock

- Shock : 1500G, duration 0.5ms, Half Sine Wave
- Vibration : 7~800Hz, 3.08Grms, 30min/axis(X,Y,Z)
- * Applicable only for cased product

●MTBF

– 1,500,000 Hours

●Weight

- 256/512GB/1TB
- Max 8g

●SSD Functional Block Diagram

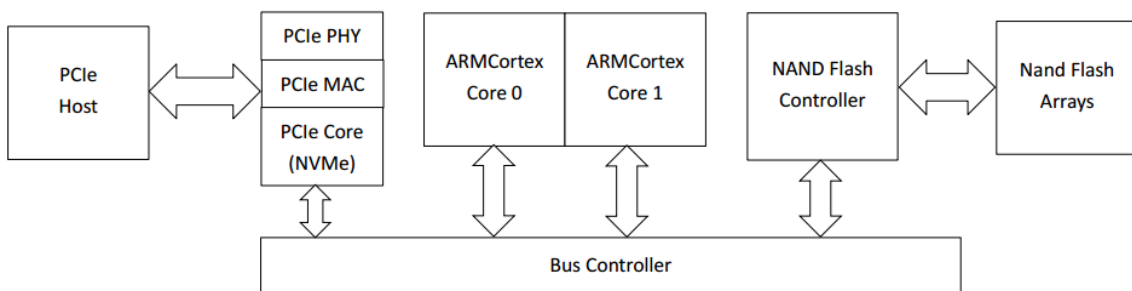

[Figure 1-1] SSD Functional Block Diagram

2. Mechanical Specification

2.1 M.2 2280 SSD physical dimensions and Weight

Capacity	Height (mm)	Width (mm)	Length (mm)	Weight (gram)
256/512GB/1TB	MAX 2.25	22.00±0.15	80.00±0.15	MAX 8g

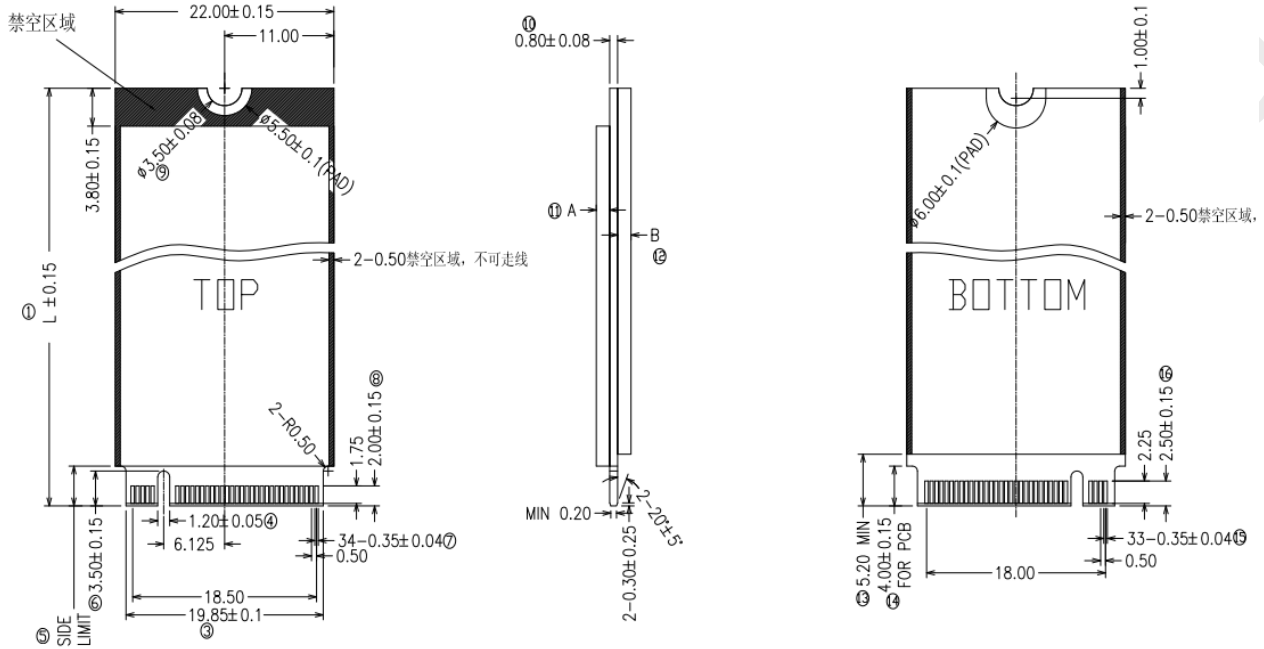

L	A (MAX)	B (MAX)
80	1.35	0

[Figure 2-1] M.2 2280 Physical dimension

3. Product Specifications

3.1 Capacity

Nominal Capacity	256GB	512GB	1TB
Unformatted Capacity	238.47GB	476.94GB	953.87GB
User-Addressable Sectors	500118192	1000215216	2000409264
Bytes per Sector	512 Bytes		

[Table 3-1] User Addressable Sectors

NOTE:

- 1 Megabyte (MB) = 1 Million bytes; 1 Gigabyte (GB) =1 Billion bytes
- 2 User Addressable Sectors in LBA mode is calculated by IDEMA rule.

3.2 Performance

Parameter	Unit	256GB	512GB	1TB
Sequential Read (Max)	MB/S	1900	2000	2000
Sequential Write (Max)	MB/S	1100	1500	1800
Random Read (4K) QD=32 (Max)	IOPS	88000	94000	94000
Random Write (4K) QD=32 (Max)	IOPS	70000	57000	75000

[Table 3-2] Drive Performance

* Actual performance may vary depending on use conditions and environment

* Note

- 1. Performance measured using CrystalDiskMark 6.0.2 x64
- 2. Write cache enabled
- 3. 1MB/sec = 1,048,576 bytes/sec was used in sequential performance
 - System: Intel Z270 Chipset, Intel Core i7-7700K@4.2GHz, 8GB DDR4
 - OS: Windows 10 x64 with HMB turn on.

3.3 System Power Consumption

Input Voltage 3.3V±5%				
Parameter		256GB	512GB	1TB
Active(Typical,RMS)	Read	3500mW		
	Write	3500mW		
Idle		1200mW		
L1.2		5mW		

[Table 3-3] Power Consumption

- CPU : Intel Core i7-7700K@4.2GHz
- DRAM : 8GB DDR4
- Chipset : Intel Z270 Chipset
- OS : Windows 10 x64
- Test Tool : CrystalDiskMark 6.0.2 x64

3.4 Supply Voltage

Item	Requirements
Allowable voltage	3.3V ± 5%
Allowable noise/ripple	100mV p-p or less

[Table 3-4] Voltage Requirements

3.5 System Reliability

Capacity	MTBF
256GB	1,500,000 Hours
512GB	
1TB	

[Table 3-5] MTBF Specifications

MTBF is Mean Time Between Failure. As same word, annual failure ratio is 0.4%.

3.6 Endurance

TBW		
256GB	512GB	1TB
500TB	1000TB	2000TB

[Table 3-6] Endurance Specifications

Notes:

1-TBW (Terabytes Written) is a measurement of SSDs’ expected lifespan, which represents the amount of data written to the device. To calculate the TBW of a SSD, the following equation is applied:

$$TBW = [(NAND\ Endurance) \times (SSD\ Capacity)] / WAF$$

NAND Endurance: NAND endurance refers to the P/E (Program/Erase) cycle of a NAND flash.

SSD Capacity: The SSD capacity is the specific capacity in total of a SSD.

WAF: Write Amplification Factor (WAF) is a numerical value representing the ratio between the amount of data that a SSD controller needs to write and the amount of data that the host’s flash controller writes. A better WAF, which is near 1, guarantees better endurance and lower frequency of data written to flash memory.

2-The above TBW values are calculated based on WAF=1.

3-TBW may differ according to flash configuration and platform.

4-The endurance of SSD could be estimated based on user behavior, NAND endurance cycles, and write amplification factor. It is not guaranteed by flash vendor.

3.7 Environmental Specifications

Features	Operating	Non-Operating
Temperature	0°C to 70°C	-40°C to 85°C
Humidity	5% to 95%, non-condensing	
Vibration	7~800Hz, 3.08Grms, 30min/axis(X,Y,Z)	
Shock	1500G, duration 0.5ms, Half Sine Wave	

[Table 3-7] Environmental Specifications

Notes:

- 1-Measured by SMART Temperature. Proper airflow recommended.
- 2-Humidity is measured in non-condensing.
- 3-Test condition for shock: 0.5ms duration with half sine wave.
- 4-Test condition for vibration: 10Hz to 2,000Hz, 15mins/axis on 3axis.

4. Electrical Interface Specification

4.1 Connector Dimension and Pin Location

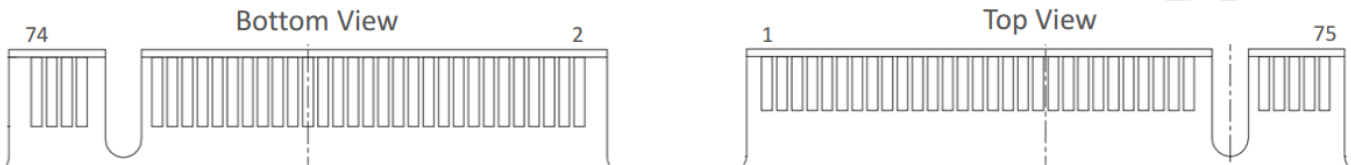

[Figure 4-1] M.2 2280 Signal and Power pins

4.2 M.2 2280 Pin Assignments and Definition

Pin #	Assignment	Description	Pin #	Assignment	Description
1	GND	Ground	2	3.3V	3.3V source
3	GND	Ground	4	3.3V	3.3V source
5	PETn3	PCIe TX	6	N/C	N/C
7	PETp3	PCIe TX	8	N/C	N/C
9	GND	Ground	10	LED_1#	Device Active Signal
11	PERn3	PCIe RX	12	3.3V	3.3V source
13	PERp3	PCIe RX	14	3.3V	3.3V source
15	GND	Ground	16	3.3V	3.3V source
17	PETn2	PCIe TX	18	3.3V	3.3V source
19	PETp2	PCIe TX	20	N/C	N/C
21	GND	Ground	22	N/C	N/C
23	PERn2	PCIe RX	24	N/C	N/C
25	PERp2	PCIe RX	26	N/C	N/C
27	GND	Ground	28	N/C	N/C
29	PETn1	PCIe TX	30	N/C	N/C
31	PETp1	PCIe TX	32	N/C	N/C
33	GND	Ground	34	N/C	N/C
35	PERn1	PCIe RX	36	N/C	N/C
37	PERp1	PCIe RX	38	N/C	N/C
39	GND	Ground	40	N/C	N/C
41	PETn0	PCIe TX	42	N/C	N/C
43	PETp0	PCIe TX	44	N/C	N/C
45	GND	Ground	46	N/C	N/C
47	PERn0	PCIe RX	48	N/C	N/C

Pin #	Assignment	Description	Pin #	Assignment	Description
49	PERp0	PCIe RX	50	PERST#	PCIe Reset
51	GND	Ground	52	CLKREQ#	PCIe Device Clock Request
53	REFCLKN	PCIe Reference Clock	54	N/C	N/C
55	REFCLKP	PCIe Reference Clock	56	N/C	N/C
57	GND	Ground	58	N/C	N/C
59	N/C	Mechanical Notch	60	N/C	Mechanical Notch
61	N/C	Mechanical Notch	62	N/C	Mechanical Notch
63	N/C	Mechanical Notch	64	N/C	Mechanical Notch
65	N/C	Mechanical Notch	66	N/C	Mechanical Notch
67	N/C	N/C	68	N/C	N/C
69	N/C	N/C	70	3.3V	3.3V source
71	GND	Ground	72	3.3V	3.3V source
73	GND	Ground	74	3.3V	3.3V source
75	GND	Ground			

[Table 4-1] M.2 2280 Connector Pin Assignment

5. Supported Command Set and Feature

The Admin command sets and NVM I/O command sets of FORESEE SSD P700 are defined in compliant with NVM Express specification revision 1.3.

5.1 Admin Command Set

Opcode(Hex)	Command Name
00h	Delete I/O Submission Queue
01h	Create I/O Submission Queue
02h	Get Log Page
04h	Delete I/O Completion Queue
05h	Create I/O Completion Queue
06h	Identify
08h	Abort
09h	Set Features
0Ah	Get Features
0Ch	Asynchronous Event Request
10h	Firmware Commit
11h	Firmware Image Download
80h	Format NVM

[Table 5-1] Admin command

5.2 NVM Express I/O Command Set

Opcode(Hex)	Command Name
00h	Flush
01h	Write

02h	Read
08h	Write Zeroes
09h	Dataset Management

[Table 5-2] NVMe I/O command

5.3 Log Page Identifiers Support

Log Identifier (Hex)	Description
01h	Error Information
02h	SMART / Health Information
03h	Firmware Slot Information

[Table 5-3] Log Identifier

5.4 Feature Identifiers Support

Feature Identifier (Hex)	Description
04h	Temperature Threshold
07h	Number of Queues
08h	Interrupt Coalescing
09h	Interrupt Vector Configuration
0Dh	Host Memory Buffer

[Table 5-4] Feature Identifier

5.5 SMART/Health Information

Bytes	Description
0	Critical Warning
2:1	Composite Temperature
3	Available Spare
4	Available Spare Threshold
5	Percentage Used
31:6	Reserved
47:32	Data Units Read
63:48	Data Units Written
79:64	Host Read Commands
95:80	Host Write Commands
111:96	Controller Busy Time
127:112	Power Cycles
143:128	Power On Hours
159:144	Unsafe Shutdowns
175:160	Media and Data Integrity Errors
191:176	Number of Error Information Log Entries
195:192	Warning Composite Temperature Time
199:196	Critical Composite Temperature Time
201:200	Temperature Sensor 1

203:202	Temperature Sensor 2
205:204	Temperature Sensor 3
207:206	Temperature Sensor 4
209:208	Temperature Sensor 5
211:210	Temperature Sensor 6
213:212	Temperature Sensor 7
215:214	Temperature Sensor 8
219:216	Thermal Management Temperature 1 Transition Count
223:220	Thermal Management Temperature 2 Transition Count
227:224	Total Time For Thermal Management Temperature 1
231:228	Total Time For Thermal Management Temperature 2
511:232	Reserved

[Table 5-5] SMART Information

5.6 Identify Command

The Identify Command returns the data described below.

Bytes	Default value	Description
0-1	126F	PCI Vendor ID (VID)
2-3	126F	PCI Subsystem Vendor ID (SSVID)
4-23	-	Serial Number
24-63	-	Model Number
64-71	-	Firmware Revision
72	6	Recommended Arbitration Burst (RAB)
73-75	0	IEEE OUI Identifier (IEEE)
76	0	Multi-Interface Capabilities
	0	Bit 7:3 - Reserved
	0	Bit 2 - SR-IOV Virtual or PCI Function
	0	Bit 1 - NVM subsystem connect to host
	0	Bit 0 - NVM subsystem contain NVM subsystem port
77	6	Maximum Data Transfer Size
78-79	1	Controller ID
80-83	10300	Version
	0	Bit 31:24 - Tertiary Version
	3	Bit 23:16 - Minor Version
	1	Bit 15:0 - Major Version
84-87	249F0	RTD3 Resume Latency
88-91	13880	RTD3 Entry Latency
92-95	200	Optional Asynchronous Events Supported
	0	Bit 31:10 - Reserved
	1	Bit 9 - Firmware Attribute Support
	0	Bit 8 - Namespace Attribute Changed Support
	0	Bit 7:0 - Reserved
96-99	0	Controller Attributes (CTRATT)
	0	Bit 31:2 - Reserved
	0	Bit 1 - Non-Operational Power State Permissive Mode Support

	0	Bit 0 - 128-bit Host Identifier Support
112-127	0	FRU Globally Unique Identifier (FGUID)
256-257	7	Optional Admin Command Support (OACS)
	0	Bit 15:9 - Reserved
	0	Bit 8 - Support Doorbell Buffer Config
	0	Bit 7 - Support Virtualization Management
	0	Bit 6 - Support NVMe-MI Send and NVMe-MI Receive
	0	Bit 5 - Support Directives
	0	Bit 4 - Support Device Self-test
	0	Bit 3 - Support Namespace Management and Namespace Attachment
	1	Bit 2 - Support Firmware Commit and Firmware Image Download
	1	Bit 1 - Support Format NVM
	1	Bit 0 - Support Security Send Receive
258	4	Abort Command Limit
259	8	Asynchronous Event Request Limit
260	12	Firmware Updates
	0	Bit 7:5 - Reserved
	1	Bit 4 - Firmware activation without a reset
	1	Bit 3:1 - Number FW Slots Support
	0	Bit 0 - Is FW Slot Read Only
261	7	Log Page Attributes
	0	Bit 7:4 - Reserved
	0	Bit 3 - Support Telemetry
	1	Bit 2 - Support extended data
	1	Bit 1 - Support Commands Supported and Effects
	1	Bit 0 - Support SMART Per Namespace
262	3F	Error Log Page Entries
263	0	Number of Power States Support
264	0	Admin Vendor Specific Cmd Configuration
	0	Bit 7:1 - Reserved
	0	Bit 0 - Admin Vendor Specific CMD Format
265	1	Autonomous Power State Transition Attributes
	0	Bit 7:1 - Reserved
	1	Bit 0 - Autonomous Power State Transitions Support
266-267	157	Warning Composite Temperature Threshold
268-269	161	Critical Composite Temperature Threshold
270-271	64	Maximum Time Firmware Activation
272-275	4000	Host Memory Buffer Preferred Size
276-279	2000	Host Memory Buffer Minimum Size
280-295	0	Total NVM Capacity
296-311	0	Unallocated NVM Capacity
312-315	0	Replay Protected Memory Block Support
	0	Bit 31:24 - Access Size
	0	Bit 23:16 - Total Size

	0	Bit 15:6 - Reserved
	0	Bit 5:3 - Authentication Method
	0	Bit 2:0 - Number of RPMB Units
316-317	0	Extended Device Self-test Time (EDSTT)
318	0	Device Self-test Options (DSTO)
319	4	Firmware Update Granularity (FWUG)
320-321	0	Keep Alive Support (KAS)
322-323	1	Host Controlled Thermal Management Attributes (HCTMA)
	0	Bit 15:1 - Reserved
	1	Bit 0 - Supports host controlled thermal management
324-325	0	Minimum Thermal Management Temperature (MNTMT)
326-327	0	Maximum Thermal Management Temperature (MXTMT)
328-331	0	Sanitize Capabilities (SANICAP)
	0	Bit 31:3 - Reserved
	0	Bit 2 - Supports Overwrite sanitize operation
	0	Bit 1 - Supports Block Erase sanitize operation
	0	Bit 0 - Supports Crypto Erase sanitize operation
332-511	0	Reserved
512	66	Submission Queue Entry Size
	6	Bit 7:4 - Maximum Entry Size
	6	Bit 3:0 - Minimum Entry Size
513	44	Completion Queue Entry Size
	4	Bit 7:4 - Maximum Entry Size
	4	Bit 3:0 - Minimum Entry Size
514-515	0	Maximum Outstanding Commands (MAXCMD)
516-519	1	Number of Namespaces
520-521	1F	Optional NVM Command Support
	0	Bit 15:7 - Reserved
	0	Bit 6 - Supports Timestamp feature
	0	Bit 5 - Supports reservations
	1	Bit 4 - Supports Save field set to a non-zero value
	1	Bit 3 - Supports the Write Zeroes
	1	Bit 2 - Supports Dataset Management
	1	Bit 1 - Supports Write Uncorrectable
	1	Bit 0 - Supports Compare
522-523	0	Fused Operation Support
	0	Bit 15:1 - Reserved
	0	Bit 0 - Compare and Write Fused Operation Support
524	1	Format NVM Attributes
	0	Bit 7:3 - Reserved
	0	Bit 2 - cryptographic Erase Support
	0	Bit 1 - secure Erase All Namespaces Support
	1	Bit 0 - format All Namespaces Support
525	1	Volatile Write Cache

	0	Bit 7:1 - Reserved
	1	Bit 0 - NVM Vendor Specific CMD Format
526-527	0	Atomic Write Unit Normal
528-529	0	Atomic Write Unit Power Fail
530	0	NVM Vendor Specific Command Configuration
	0	Bit 7:1 - Reserved
	0	Bit 0 - NVM Vendor Specific CMD Format
532-533	0	Atomic Compare and Write Unit
536-539	0	SGL Support
	0	Bit 31:21 - Reserved
	0	Bit 20 - Supports the Address field in SGL Data Block
	0	Bit 19 - Supports MPTR contains SGL Descriptor
	0	Bit 18 - Supports contain a large data or metadata SGL
	0	Bit 17 - Byte Aligned Contiguous Buffer Support
	0	Bit 16 - SGL Bit Bucket Descriptor Support
	0	Bit 15:3 - Reserved
	0	Bit 2 - Supports the Keyed SGL Data Block descriptor
	0	Bit 1-0 - SGL Support for NVM Command Set
768-1023	0	NVM Subsystem NVMe Qualified Name (SUBNQN)
2048-2079	-	Power State 0 Descriptor
	0	Bit 255:125 - Reserved
	0	Bit 124:120 - Relative Write Latency
	0	Bit 119:117 - Reserved
	0	Bit 116:112 - Relative Write Throughput
	0	Bit 111:109 - Reserved
	0	Bit 108:104 - Relative Read Latency
	0	Bit 103:101 - Reserved
	0	Bit 100:96 - Relative Read Throughput
	0	Bit 95:64 - Exit Latency
	0	Bit 63:32 - Entry Latency
	0	Bit 31:26 - Reserved
	0	Bit 25 - Non-Operational State
	0	Bit 24 - Max Power Scale
	0	Bit 23:16 - Reserved
	384	Bit 15:0 - Maximum Power
2080-2111	-	Power State 1 Descriptor
	0	Bit 255:125 - Reserved
	0	Bit 124:120 - Relative Write Latency
	0	Bit 119:117 - Reserved
	0	Bit 116:112 - Relative Write Throughput
	0	Bit 111:109 - Reserved
	0	Bit 108:104 - Relative Read Latency
	0	Bit 103:101 - Reserved
	0	Bit 100:96 - Relative Read Throughput

	0	Bit 95:64 - Exit Latency
	0	Bit 63:32 - Entry Latency
	0	Bit 31:26 - Reserved
	0	Bit 25 - Non-Operational State
	0	Bit 24 - Max Power Scale
	0	Bit 23:16 - Reserved
	0	Bit 15:0 - Maximum Power
2112-2143	-	Power State 2 Descriptor
	0	Bit 255:125 - Reserved
	0	Bit 124:120 - Relative Write Latency
	0	Bit 119:117 - Reserved
	0	Bit 116:112 - Relative Write Throughput
	0	Bit 111:109 - Reserved
	0	Bit 108:104 - Relative Read Latency
	0	Bit 103:101 - Reserved
	0	Bit 100:96 - Relative Read Throughput
	0	Bit 95:64 - Exit Latency
	0	Bit 63:32 - Entry Latency
	0	Bit 31:26 - Reserved
	0	Bit 25 - Non-Operational State
	0	Bit 24 - Max Power Scale
	0	Bit 23:16 - Reserved
2144-2175	-	Power State 3 Descriptor
	0	Bit 255:125 - Reserved
	0	Bit 124:120 - Relative Write Latency
	0	Bit 119:117 - Reserved
	0	Bit 116:112 - Relative Write Throughput
	0	Bit 111:109 - Reserved
	0	Bit 108:104 - Relative Read Latency
	0	Bit 103:101 - Reserved
	0	Bit 100:96 - Relative Read Throughput
	0	Bit 95:64 - Exit Latency
	0	Bit 63:32 - Entry Latency
	0	Bit 31:26 - Reserved
	0	Bit 25 - Non-Operational State
	0	Bit 24 - Max Power Scale
	0	Bit 23:16 - Reserved
2176-2207	-	Power State 4 Descriptor
	0	Bit 255:125 - Reserved
	0	Bit 124:120 - Relative Write Latency
	0	Bit 119:117 - Reserved
	0	Bit 116:112 - Relative Write Throughput

0	Bit 111:109 - Reserved
0	Bit 108:104 - Relative Read Latency
0	Bit 103:101 - Reserved
0	Bit 100:96 - Relative Read Throughput
0	Bit 95:64 - Exit Latency
0	Bit 63:32 - Entry Latency
0	Bit 31:26 - Reserved
0	Bit 25 - Non-Operational State
0	Bit 24 - Max Power Scale
0	Bit 23:16 - Reserved
0	Bit 15:0 - Maximum Power

[Table 5-6] Identify Data Structure

6. Product Line up

Type	Capacity	MODEL	Part Number
PCIe M.2 2280 SSD	256GB	P78AF256G	FSB0C256G-35C6600
PCIe M.2 2280 SSD	512GB	P78AF512G	FSB0C512G-35C6600
PCIe M.2 2280 SSD	1TB	P78AF001T	FSB0C001T-35C6600

7. Contact information

Tel: +86-755-8616-8848

Fax: +86-755-8616-9388

Email: sales@longsys.com

Website: www.longsys.com

Add: 8/F, 1 Building, Finance Base, No.8, Kefa Road, High-Tech Park, Shenzhen, China