

FORESEE 8GB DDR4 3200 SO-DIMM Datasheet

Version: 1.0

LONGSYS ELECTRONICS RESERVES THE RIGHT TO CHANGE PRODUCTS INFORMATION AND SPECIFICATIONS WITHOUT NOTICE.

Products and specifications discussed herein are for reference purposes only. All information discussed herein is provided on an "AS IS" basis, without warranties of any kind.

This document and all information discussed herein remain the sole and exclusive property of Longsys Electronics. No license of any patent, copyright, mask work, trademark or any other intellectual property right is granted by one party to the other party under this document, by implication, estoppel or other-wise.

Longsys products are not intended for use in life support, critical care, medical, safety equipment, or similar applications where product failure could result in loss of life or personal or physical harm, or any military or defense application, or any governmental procurement to which special terms or provisions may apply.

For updates or additional information about Longsys products, contact your nearest Longsys office.

All brand names, trademarks and registered trademarks belong to their respective owners.

© 2020 Shenzhen Longsys Electronics Co., Ltd. All rights reserved.

Revision History

Revision No.	History	Draft Date	Remark
1.0	Release	Apr 2021	

Longsys Confidential

Table of content

1. Description	5
2. Features	5
3. Ordering Information	6
4. Key Parameters	6
5. Address Table	6
6. DRAM Component Operating Temperature Range	8
7. Absolute Maximum DC Ratings	8
8. AC & DC Operating Conditions	8
9. x8 Package Pinout (Top view) : 78ball FBGA Package	9
10. Pin Descriptions	10
11. Input/Output Functional Descriptions	11
12. Pin Assignments	14
13. DDR4-3200 Speed Bins and Operations	16
14. Trouble shooting Guide	17
15. Functional Diagram	19
16. PCB Specifications	20
17. Module Dimensions	21

1. Description

FORESEE Unbuffered Small Outline DDR4 SDRAM DIMMs (Unbuffered Small Outline Double Data Rate Syn-chronous DRAM Dual In-Line Memory Modules) are low power, high-speed operation memory modules that use DDR4 SDRAM devices. These DDR4 SDRAM Unbuffered Small Outline DIMMs are intended for use as main memory when installed in systems such as micro servers and mobile personal computers.

2. Features

- VDD = VDDQ = 1.2V ± 60mV
- 16 Banks (4 Bank Groups)
- 8-bit pre-fetch
- On Die Termination using ODT pin
- (Data Bus Inversion)
- CRC (Cyclic Redundancy Check) for Read/Write data security
- Internal VREF for data inputs
- External VPP for DRAM Activating Power
- capabilityPPR and sPPR is supported
- All of Lead-Free products are compliant for RoHS

3. Ordering Information

Part Number	Density	Speed	Component Composition	# of ranks
FD4AS3200C8GTG	8GB	DDR4 3200	1Gx8*8	1

4. Key Parameters

Grade	Speed (Mbps)	tCK (ns)	CAS Latency (tCK)	tRCD (ns)	tRP (ns)	tRAS (ns)	tRC (ns)	CL-tRCD-tRP
3200AA	3200	0.625	22	13.75	13.75	32	45.75	22-22-22

5. Address Table

	1G*8
Number of Bank Groups	4
Bank group Address	BG[1:0]
Bank Address in a BG	BA[1:0]
Row Address	64K A[15:0]
Column Address	1K A[9:0]
Page size	1 KB

F D4 A S 3200 C 8G T G

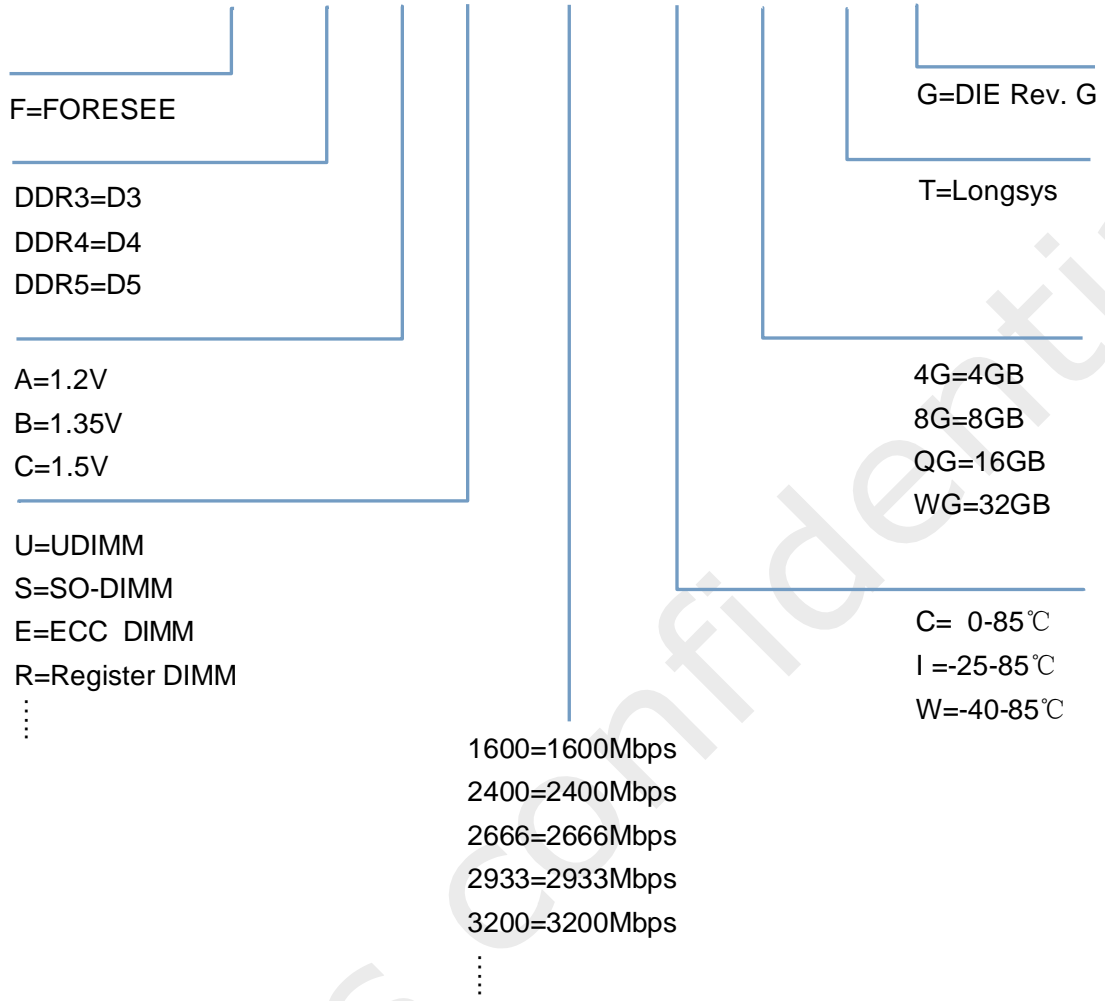

6. DRAM Component Operating Temperature Range

Symbol	Parameter	Rating	Units
T _{OPER}	Normal Operating Temperature Range	0 to 85	°C

Notes:

- Operating Temperature T_{OPER} is the case surface temperature on the center/top side of the DRAM.
- The Normal Temperature Range specifies the temperatures where all DRAM specifications will be supported. During operation, the DRAM case temperature must be maintained between 0-85°C under all operating conditions.

7. Absolute Maximum DC Ratings

Absolute Maximum DC Ratings

Symbol	Parameter	Rating	Units
VDD	Voltage on VDD pin relative to Vss	-0.4 ~ 1.5	V
VDDQ	Voltage on VDDQ pin relative to Vss	-0.4 ~ 1.5	V
VPP	Voltage on VPP pin relative to Vss	-0.4 ~ 1.5	V
V _{IN} , V _{OUT}	Voltage on any relative to VSS	-0.4 ~ 1.5	V
V _{STG}	Storage Temperature	-55 to +100	°C

Notes:

- VDD and VDDQ must be within 300 mV of each other at all times; and VREFCA must be not greater than 0.6 x VDDQ, When VDD and VDDQ are less than 500 mV; VREFCA may be equal to or less than 300 mV
- VPP must be equal or greater than VDD/VDDQ at all times.

8. AC & DC Operating Conditions

Recommended DC Operating Conditions

Symbol	Parameter	Rating			Unit
		Min.	Typ.	Max.	
VDD	Supply Voltage	1.14	1.2	1.26	V
VDDQ	Supply Voltage for Output	1.14	1.2	1.26	V
VPP	Peak-to-Peak Voltage	2.375	2.5	2.75	V

Notes:

- Under all conditions VDDQ must be less than or equal to VDD.
- VDDQ tracks with VDD. AC parameters are measured with VDD and VDDQ tied together.
- DC bandwidth is limited to 20MHz.

9. x8 Package Pinout (Top view) : 78ball FBGA Package

	1	2	3	4	5	6	7	8	9	
A	VDD	VSSQ	TDQS_c				DM_n/DBI_n /TDQS_t	VSSQ	VSS	A
B	VPP	VDDQ	DQS_c				DQ1	VDDQ	ZQ	B
C	VDDQ	DQ0	DQS_t				VDD	VSS	VDDQ	C
D	VSSQ	DQ4	DQ2				DQ3	DQ5	VSSQ	D
E	VSS	VDDQ	DQ6				DQ7	VDDQ	VSS	E
F	VDD	NC	ODT				CK_t	CK_c	VDD	F
G	VSS	NC	CKE				CS_n	NC	TEN	G
H	VDD	WE_n/A14	ACT_n				CAS_n/A15	RAS_n	VSS	H
J	VREFCA	BG0	A10/AP				A12/BC_n	BG1	VDD	J
K	VSS	BA0	A4				A3	BA1	VSS	K
L	RESET_n	A6	A0				A1	A5	ALERT_n	L
M	VDD	A8	A2				A9	A7	VPP	M
N	VSS	A11	PAR				NC	A13	VDD	N
	1	2	3	4	5	6	7	8	9	

10. Pin Descriptions

Pin Name	Description	Pin Name	Description
A0–A17 ¹	SDRAM address input	SCL	I ² C serial bus clock for SPD/TS and register
BA0, BA1	SDRAM bank select input	SDA	I ² C serial data line for SPD/TS and register
BG0, BG1	Register bank group select input	SA0–SA2	I ² C slave address select for SPD/TS and register
RAS_n ²	Register row address strobe input	PAR	Register parity input
CAS_n ³	Register column address strobe input	VDD	SDRAM core power
WE_n ⁴	Register write enable input		
CS0_n, CS1_n, CS2_n, CS3_n	DIMM Rank Select Lines input	12 V	Optional Power Supply on socket but not used on RDIMM
CKE0, CKE1	Register clock enable lines input	VREFCA	SDRAM command/address reference supply
ODT0, ODT1	Register on-die termination control lines input	VSS	Power supply return (ground)
ACT_n	Register input for activate input	VDDSPD	Serial SPD/TS positive power supply
DQ0–DQ63	DIMM memory data bus	ALERT_n	Register ALERT_n output
CB0–CB7	DIMM ECC check bits	VPP	SDRAM Supply
TDQS9_t–TDQS17_t TDQS_c–TDQS17_c	Dummy loads for mixed populations of x4 based and x8 based RDIMMs.		
DQS0_t–DQS17_t	Data Buffer data strobes (positive line of differential pair)	RESET_n	Set Register and SDRAMs to a Known State
DBI0_n–DBI8_n	Data Bus Inversion	EVENT_n	SPD signals a thermal event has occurred
CK0_t, CK1_t	Register clock input (positive line of differential pair)	VTT	SDRAM I/O termination supply
CK0_c, CK1_c	Register clock input (negative line of differential pair)	RFU	Reserved for future use

11. Input/Output Functional Descriptions

Symbol	Type	Function
CK0/#CK0 CK1/#CK1	IN	Clock: CK_t and CK_c are differential clock inputs. All address and control input signals are sampled on the crossing of the positive edge of CK_t and negative edge of CK_c.
CKE0, CKE1	Input	Clock Enable: CKE HIGH activates, and CKE Low deactivates, internal clock signals and device input buffers and output drivers. Taking CKE Low provides Precharge Power-Down and Self-Refresh operation (all banks idle), or Active Power-Down (row Active in any bank). CKE is synchronous for Self-Refresh exit. After VREFCA and Internal DQ Vref have become stable during the power on and initialization sequence, they must be maintained during all operations (including Self-Refresh). CKE must be maintained high throughout read and write accesses. Input buffers, excluding CK_t,CK_c,ODT and CKE are disabled during power-down. Input buffers, excluding CKE, are disabled during Self-Refresh.
CS0_n, CS1_n, CS2_n, CS3_n	Input	Chip Select: All commands are masked when CS_n is registered HIGH. CS_n provides for external Rank selection on systems with multiple Ranks. CS_n is considered part of the command code.
C0, C1, C2	Input	Chip ID : Chip ID is only used for 3DS for 2,4,8high stack via TSV to select each slice of stacked component. Chip ID is considered part of the command code
ODT0, ODT1	Input	On Die Termination: ODT (registered HIGH) enables RTT_NOM termination resistance internal to the DDR4 SDRAM. When enabled, ODT is only applied to each DQ, DQS_t, DQS_c and DM_n/DBI_n/ TDQS_t, NU/TDQS_c (When TDQS is enabled via Mode Register A11=1 in MR1) signal for x8 conurations. For x16 conuration ODT is applied to each DQ, DQSU_t, DQSU_c, DQSL_t, DQSL_c, DMU_n, and DML_n signal. The ODT pin will be ignored if MR1 is programmed to disable RTT_NOM.
ACT_n	Input	Activation Command Input : ACT_n defines the Activation command being entered along with CS_n. The input into RAS_n/A16, CAS_n/A15 and WE_n/A14 will be considered as Row Address A16, A15 and A14
RAS_n/A16, CAS_n/A15, WE_n/A14	Input	Command Inputs: RAS_n/A16, CAS_n/A15 and WE_n/A14 (along with CS_n) define the command being entered. Those pins have multi function. For example, for activation with ACT_n Low, those are Addressing like A16,A15 and A14 but for non-activation command with ACT_n High, those are Command pins for Read, Write and other command defined in command truth table

Symbol	Type	Function
DM_n/DBI_n/ TDQS_t, (DMU_n/ DBIU_n), (DML_n/ DBIL_n)	Input/ Output	Input Data Mask and Data Bus Inversion: DM_n is an input mask signal for write data. Input data is masked when DM_n is sampled LOW coincident with that input data during a Write access. DBI_n is an input/output identifying whether to store/output the true or inverted data. If DBI_n is LOW, the data will be stored/output after inversion inside the DDR4 SDRAM and not inverted if DBI_n is HIGH. TDQS is only supported in x8 SDRAM configurations. TDQS is not valid for UDIMMs.
BG0, BG1	Input	Bank Group Inputs: BG0 - BG1 define which bank group an Active, Read, Write or Precharge command is being applied. BG0 also determines which mode register is to be accessed during a MRS cycle. x4/x8 SDRAM configurations have BG0 and BG1. x16 based SDRAMs only have BG0.
BA0, BA1	Input	Bank Address Inputs: BA0 - BA1 define to which bank an Active, Read, Write or Precharge command is being applied. Bank address also determines which mode register is to be accessed during a MRS cycle.
A0 - A17	Input	Address Inputs: Provide the row address for ACTIVATE Commands and the column address for Read/Write commands to select one location out of the memory array in the respective bank. A10/AP, A12/BC_n, RAS_n/A16, CAS_n/A15 and WE_n/A14 have additional functions. See other rows. The address inputs also provide the op-code during Mode Register Set commands. A17 is only defined for the x4 SDRAM configuration.
A10 / AP	Input	Auto-precharge: A10 is sampled during Read/Write commands to determine whether Autoprecharge should be performed to the accessed bank after the Read/Write operation. (HIGH: Autoprecharge; LOW: no Autoprecharge). A10 is sampled during a Precharge command to determine whether the Precharge applies to one bank (A10 LOW) or all banks (A10 HIGH). If only one bank is to be precharged, the bank is selected by bank addresses.
A12 / BC_n	Input	Burst Chop: A12/BC_n is sampled during Read and Write commands to determine if burst chop (on-the-fly) will be performed. (HIGH, no burst chop; LOW: burst chopped). See command truth table for details.
RESET_n	CMOS Input	Active Low Asynchronous Reset: Reset is active when RESET_n is LOW, and inactive when RESET_n is HIGH. RESET_n must be HIGH during normal operation.
DQ	Input / Output	Data Input/ Output: Bi-directional data bus. If CRC is enabled via Mode register then CRC code is added at the end of Data Burst. Any DQ from DQ0~DQ3 may indicate the internal Vref level during test via Mode Register Setting MR4 A4=High. During this mode, RTT value should be set to Hi-Z. Refer to vendor specific datasheets to determine which DQ is used.
PARITY	Input	Command and Address Parity Input: DDR4 Supports Even Parity check in DRAMs with MR setting. Once it's enabled via Register in MR5, then DRAM calculates Parity with ACT_n, RAS_n/A16, CAS_n/A15, WE_n/A14, BG0-BG1, BA0-BA1, A16-A0. Input parity should be maintained at the rising edge of the clock and at the same time with command & address with CS_n LOW

Symbol	Type	Function
DQS_t, DQS_c, DQSU_t, DQSU_c, DQSL_t, DQSL_c	Input/ Output	Data Strobe: output with read data, input with write data. Edge-aligned with read data, centered in write data. For the x16, DQSL corresponds to the data on DQL0-DQL7; DQSU corresponds to the data on DQU0-DQU7. The data strobe DQS_t, DQSL_t and DQSU_t are paired with differential signals DQS_c, DQSL_c, and DQSU_c, respectively, to provide differential pair signaling to the system during reads and writes. DDR4 SDRAM supports differential data strobe only and does not support single-ended.
TDQS_t, TDQS_c	Output	Termination Data Strobe: TDQS_t/TDQS_c are not valid for UDIMMs.
ALERT_n	Output	Alert: It has multi functions such as CRC error flag, Command and Address Parity error flag as Output signal. If there is error in CRC, then ALERT_n goes LOW for the period time interval and goes back HIGH. If there is error in Command Address Parity Check, then ALERT_n goes LOW for relatively long period until on-going DRAM internal recovery transaction is complete. During Connectivity Test mode, this pin functions as an input. Using this signal or not is dependent on the system.
RFU		Reserved for Future Use. No on DIMM electrical connection is present.
NC		No Connect: No on DIMM electrical connection is present.
VDD1	Supply	Power Supply: 1.2 V +/- 0.06 V
VSS	Supply	Ground
VPP	Supply	DRAM Activating Power Supply: 2.5V (2.375V min, 2.75V max)
VTT	Supply	Power Supply for termination of Address, Command and Control, VDD/2.
12 V	Supply	12 V supply not used on UDIMMs.
VDDSPD	Supply	Power supply used to power the I2C bus on the SPD-TSE.
VREFCA	Supply	Reference voltage for CA

Note:

1. Input only pins (BG0-BG1, BA0-BA1, A0-A17, ACT_n, RAS_n/A16, CAS_n/A15, WE_n/A14, CS_n, CKE, ODT, and RESET_n) do not supply termination.

12. Pin Assignments

Pin	Front Side Pin Label	Pin	Back Side Pin Label	Pin	Front Side Pin Label	Pin	Back Side Pin Label
1	VSS	2	VSS	131	A3	132	A2
3	DQ5	4	DQ4	133	A1	134	EVENT_n
5	VSS	6	VSS	135	VDD	136	VDD
7	DQ1	8	DQ0	137	CK0_t	138	CK1_t
9	VSS	10	VSS	139	CK0_c	140	CK1_C
11	DQS0_C	12	DM0_n, DBI0_n	141	VDD	142	VDD
13	DQS0_t	14	VSS	143	PARITY	144	A0
15	VSS	16	DQ6	KEY			
17	DQ7	18	VSS				
19	VSS	20	DQ2	145	BA1	146	A10/AP
21	DQ3	22	VSS	147	VDD	148	VDD
23	VSS	24	DQ12	149	CS0_n	150	BA0
25	DQ13	26	VSS	151	A14/WE_n	152	A16/RAS_n
27	VSS	28	DQ8	153	VDD	154	VDD
29	DQ9	30	VSS	155	ODT0	156	A15/CAS_n
31	VSS	32	DQS1_C	157	CS1_n	158	A13
33	DM1_n, DBI1_n	34	DQS1_t	159	VDD	160	VDD
35	VSS	36	VSS	161	ODT1	162	C0, CS2_n, NC
37	DQ15	38	DQ14	163	VDD	164	VREFCA
39	VSS	40	VSS	165	C1, CS3_n, NC	166	SA2
41	DQ10	42	DQ11	167	VSS	168	VSS
43	VSS	44	VSS	169	DQ37	170	DQ36
45	DQ21	46	DQ20	171	VSS	172	VSS
47	VSS	48	VSS	173	DQ33	174	DQ32
49	DQ17	50	DQ16	175	VSS	176	VSS
51	VSS	52	VSS	177	DQS4_C	178	DM4_n, DBI4_n
53	DQS2_c	54	DM2_n, DBI2_n	179	DQS4_t	180	VSS
55	DQS2_t	56	VSS	181	VSS	182	DQ39
57	VSS	58	DQ22	183	DQ38	184	VSS
59	DQ23	60	VSS	185	VSS	186	DQ35
61	VSS	62	DQ18	187	DQ34	188	VSS
63	DQ19	64	VSS	189	VSS	190	DQ45
65	VSS	66	DQ28	191	DQ44	192	VSS
67	DQ29	68	VSS	193	VSS	194	DQ41
69	VSS	70	DQ24	195	DQ40	196	VSS
71	DQ25	72	VSS	197	VSS	198	DQS5_c

Pin	Front Side Pin Label	Pin	Back Side Pin Label	Pin	Front Side Pin Label	Pin	Back Side Pin Label
73	VSS	74	DQS3_c	199	DM5_n, DBI5_n	200	DQS5_t
75	DM3_n, DBI3_n	76	DQS3_t	201	VSS	202	VSS
77	VSS	78	VSS	203	DQ46	204	DQ47
79	DQ30	80	DQ31	205	VSS	206	VSS
81	VSS	82	VSS	207	DQ42	208	DQ43
83	DQ26	84	DQ27	209	VSS	210	VSS
85	VSS	86	VSS	211	DQ52	212	DQ53
87	CB5, NC	88	CB4, NC	213	VSS	214	VSS
89	VSS	90	VSS	215	DQ49	216	DQ48
91	CB1, NC	92	CB0, NC	217	VSS	218	VSS
93	VSS	94	VSS	219	DQS6_C	220	DM6_n, DBI6_n
95	DQS8_c	96	DBI8_n	221	DQS6_t	222	VSS
97	DQS8_t	98	VSS	223	VSS	224	DQ54
99	VSS	100	CB6, NC	225	DQ55	226	VSS
101	CB2, NC	102	VSS	227	VSS	228	DQ50
103	VSS	104	CB7, NC	229	DQ51	230	VSS
105	CB3, NC	106	VSS	231	VSS	232	DQ60
107	VSS	108	RESET_n	233	DQ61	234	VSS
109	CKE0	110	CKE1	235	VSS	236	DQ57
111	VDD	112	VDD	237	DQ56	238	VSS
113	BG1	114	ACT_n	239	VSS	240	DQS7_c
115	BG0	116	ALERT_n	241	DM7_n, DBI7_n	242	DQS7_t
117	VDD	118	VDD	243	VSS	244	VSS
119	A12	120	A11	245	DQ62	246	DQ63
121	A9	122	A7	247	VSS	248	VSS
123	VDD	124	VDD	249	DQ58	250	DQ59
125	A8	126	A5	251	VSS	252	VSS
127	A6	128	A4	253	SCL	254	SDA
129	VDD	130	VDD	255	VDDSPD	256	SA0
				257	VPP	258	VTT
				259	VPP	260	SA1

13. DDR4-3200 Speed Bins and Operations

Speed Bin		DDR4-3200AA		Unit
CL-nRCD-nRP		22-22-22		ns
Parameter	Symbol	min	max	ns
Internal READ command to first data	tAA	13.75	18.00	ns
Internal READ command to first data with read DBI enabled	tAA_DBI	tAA(min) + 4nCK	tAA(max) + 4nCK	ns
ACT to internal READ or WRITE delay time	tRCD	13.75	-	ns
PRE command period	tRP	13.75	-	ns
ACT to PRE command Period	tRAS	32	9 x tREFI	ns
ACT to ACT or REF command period	tRC	45.75	-	ns

14. Trouble shooting Guide

Description: DDRIV SDRAM, Single-Rank, x8-FBGA 78-Ball-based, x64 Unbuffered, 260-pin SO DIMM

Module Pin No.	Module DQ	Damping RES.	IC No.	IC DQ	Module Pin No.	Module DQ	Damping RES.	IC No.	IC DQ
8	0	R98	U1	5	28	8	R93	U9	6
7	1	R6		7	29	9	R12		4
20	2	R95		6	41	10	R15		5
21	3	R10		4	42	11	R89		7
4	4	R199		3	24	12	R94		0
3	5	R5		1	25	13	R11		2
16	6	R96		2	38	14	R90		3
17	7	R9		0	37	15	R14		1
50	16	R87	U2	5	70	24	R82	U8	6
49	17	R17		7	71	25	R23		4
62	18	R84		6	83	26	R26		5
63	19	R21		4	84	27	R78		7
46	20	R88		3	66	28	R83		0
45	21	R16		1	67	29	R22		2
58	22	R85		2	79	30	R25		1
59	23	R20		0	80	31	R79		3
174	32	R75	U4	5	195	40	R34	U7	0
173	33	R28		7	194	41	R70		2
187	34	R32		4	207	42	R37		3
186	35	R72		6	208	43	R66		1
170	36	R76		3	191	44	R33		6
169	37	R27		1	190	45	R71		4
183	38	R31		0	203	46	R36		5
182	39	R73		2	204	47	R67		7
216	48	R64	U5	5	237	56	R45	U6	6
215	49	R39		7	236	57	R59		4
228	50	R61		6	249	58	R48		5
229	51	R43		4	250	59	R55		7
211	52	R38		1	232	60	R60		0
212	53	R65		3	233	61	R44		2
224	54	R62		2	245	62	R47		1
225	55	R42		0	246	63	R56		3

First check the SPD data and EEPROM. Then check the following components for other problem.

	Clock loading	Boot failure
1-RANK	R77, RN2	SPD data, U3

Longsys Confidential

15. Functional Diagram

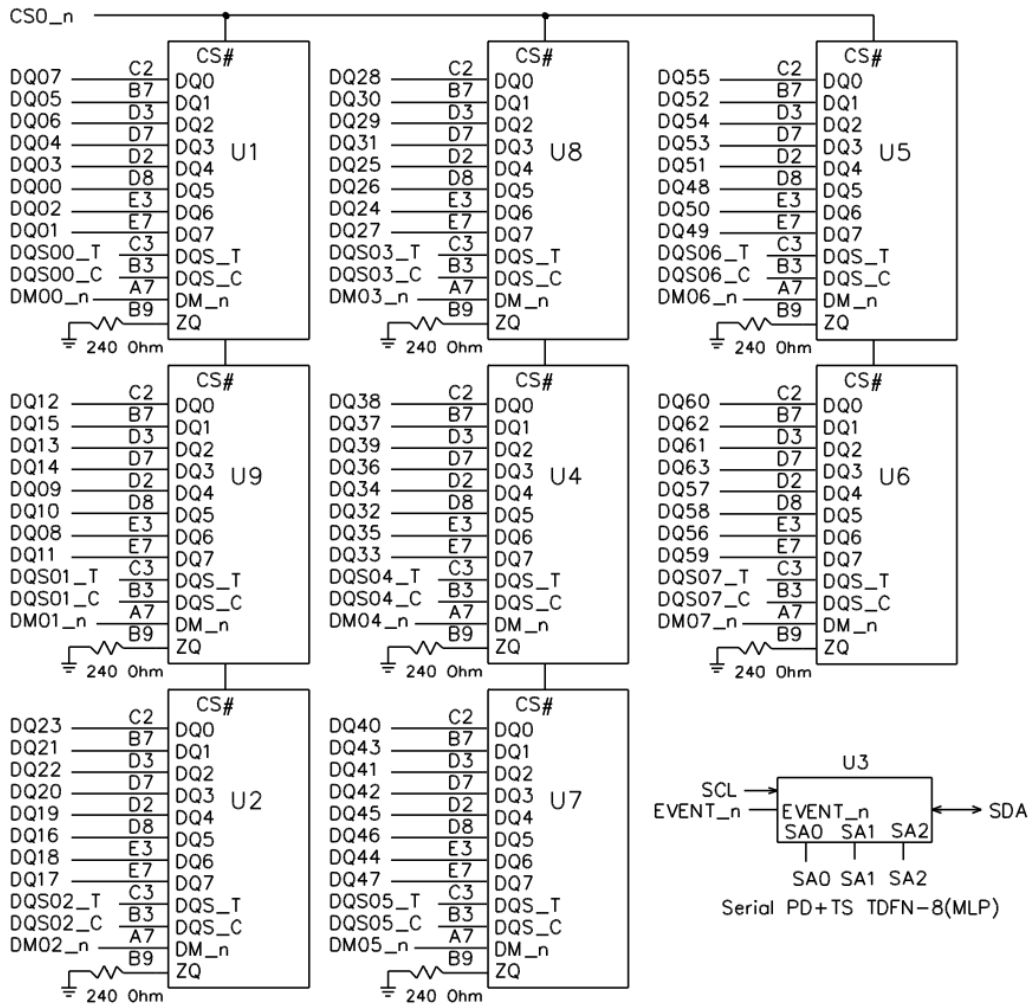

16. PCB Specifications

General

1. Board size: 69.6 x 30 mm ± 0.15 mm
2. Thickness: 1.2 ± 0.1 mm
3. Pin count: 260 PIN

PCB Material

1. RoHS
2. Glass Epoxy FR4, .UL 94V-0, BP ML or BP 4M-1

17. Module Dimensions

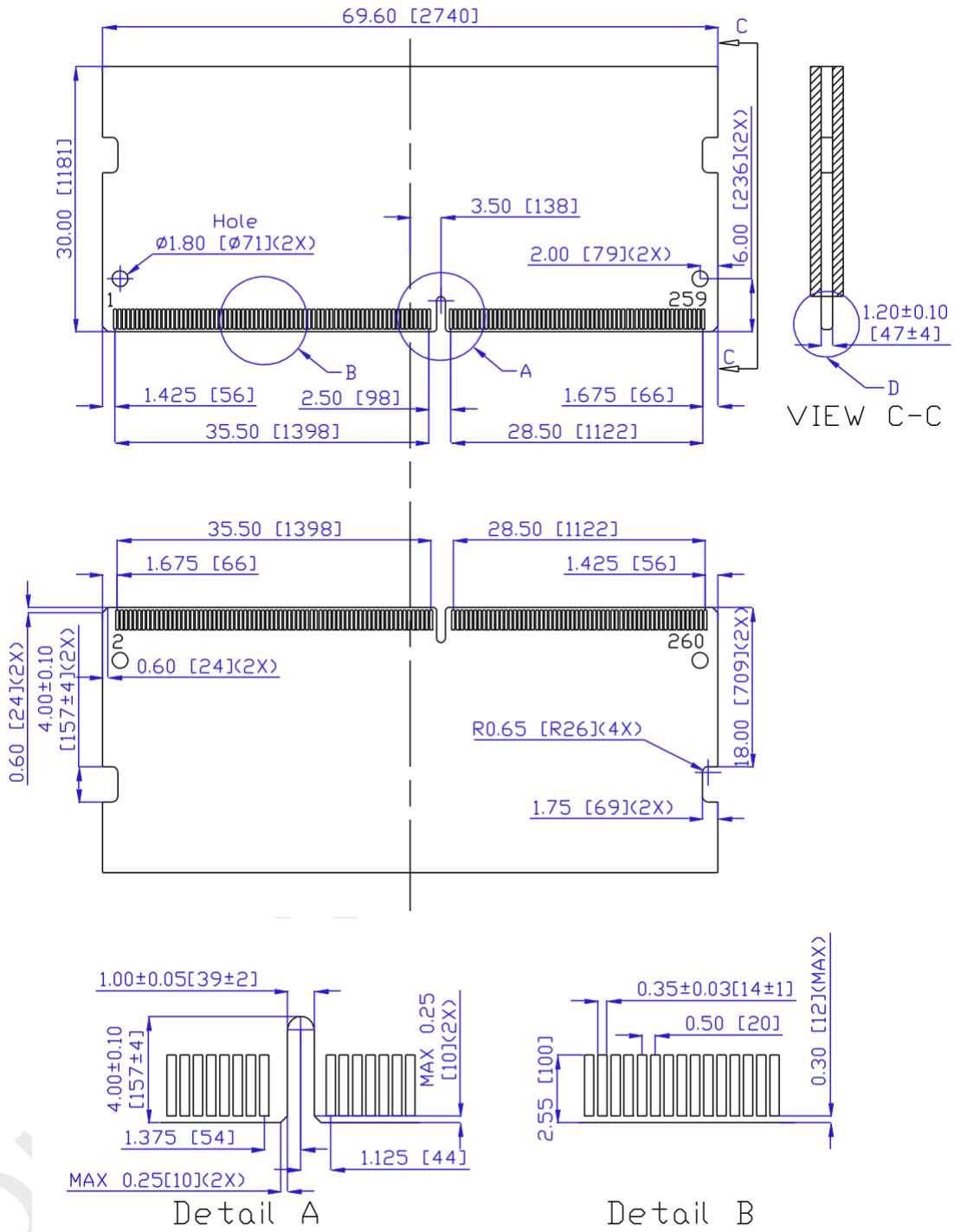

Units: millimeters